

NTN®

**Adapters
Withdrawal Sleeves
Locknuts, Lockwashers
& Lockplates
Hydraulic Nuts**

**(Mounting & Dismounting Tools
for Rolling Bearings)**

CAT. No. 4201-IV/E



NTN

Adapters Withdrawal Sleeves Locknuts, Lockwashers & Lockplates Hydraulic Nuts (Mounting & Dismounting Tools for Rolling Bearings)

CONTENTS

PAGE

1. Types and Features	2
------------------------------------	---

2~3

2. Details of Special Hydraulic Sleeve	4
---	---

4~5

3. Dimensions	Adapters	8
	Withdrawal Sleeves	22
	Locknuts, Nuts	36
	Lockwashers & Lockplates	46
	Hydraulic Nuts	50
	Protective Plates	52

7~53

4. Handling	(1) Installation/removal of adapter sleeves using locknuts ...	55
	(2) Installation/removal of bearings using hydraulic sleeves ...	57
	(3) Installation/removal of bearings using hydraulic nuts	60

54~63



Applicable Bearings

Series	Applicable Bearings (tapered bore)						Page		
	Self-Aligning Ball Bearings		Spherical Roller Bearings		Insert Bearings for Bearing Units				
H 30 HE 30 H 30··HF H 30··HB	Adapters		23024EAK } 230/500BK		—		8		
H 31 HE 31 H 31··HF H 31··HB			23122EAK } 231/500BK	22224EMK } 22264EMK	—		10		
H 2 HE 2 HS 2			1205SK } 1222SK	—		—		12	
H 32 H 32··HF H 32··HB			—		23260EMK } 23280BK	—		14	
H 3 HE 3 HS 3			1305SK } 1322SK	2205SK } 2222SK	22208EAK } 22222EAK	21308CK } 21322K	—		16
H 23 HE 23 HS 23 H 23··HF H 23··HB			2305SK } 2322SK	23218EMK } 23256EMK	22308EAK } 22356EAK	UK205 } UK218	UK305 } UK328	UKX05 } UKX20	18
H 39 H 39··HF H 39··HB			—		23932EMK } 23996BK	—		20	
AH 30 AH 30··H	Withdrawal Sleeves		23024EAK } 23096BK		—		22		
AH 31 AH 31··H			2222SK	23122EAK } 23196BK	22222EAK } 22234EMK	—		24	
AH 2			1208SK } 1222SK	—		—		26	
AH 22 AH 22··H			—		22236EMK } 22264EMK	—		27	
AH 32 AH 32··H			—		23218EAK } 23240EMK	23260EMK } 23296BK	—		28
AH 3			2208SK } 2220SK	1308SK } 1322SK	22208EAK } 22220EMK	21308CK } 21322K	—		30
AH 23 AH 23··H			2308SK } 2322SK	23244EMK } 23256EMK	22308EAK } 22356EMK	—		31	
AH 240 AH 240··H			—		24024EMK30 } 24088BK30	—		33	
AH 241 AH 241··H			—		24122EMK30 } 24192BK30	—		34	
AH 39 AH 39··H			—		23934EMK } 23996K	—		35	
AN, AN··SP, AN··SPB, ANL, ANL··SP, ANL··SPB		Locknuts (for adapter sleeve, withdrawal sleeve and shaft)					36~43		
HN, HNL		Nuts (for withdrawal sleeve and shaft)					44~45		
AW, AWL, AL, ALL		Lockwashers and Lockplates					46~49		
HPN, ANP		Hydraulic nuts (mounting & dismounting tools for rolling bearings) Protective plates					50		

1. Types and Features

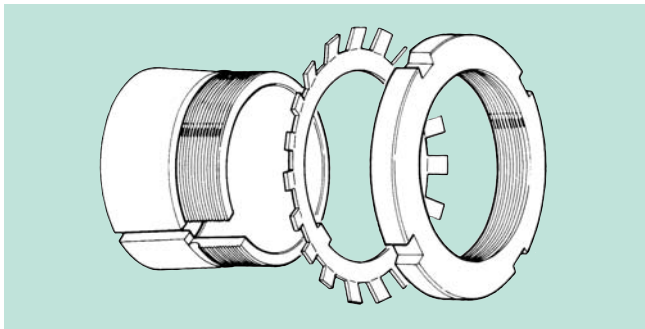

Adapters

Adapters are made up of adapter sleeves, nuts, and washers or clasps.

These adapters are used to mount tapered bore bearings easily on specific positions of shafts.

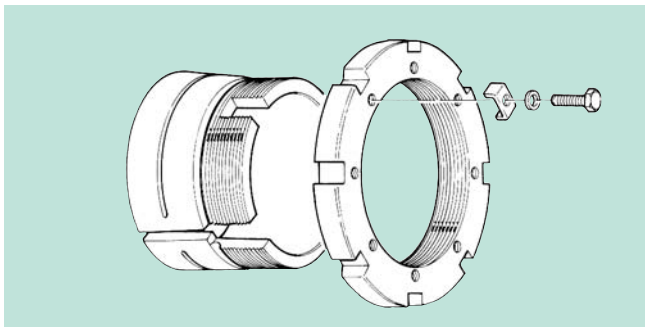

Hydraulic Adapters

Hydraulic adapters feature an oil inlet and oil groove in the sleeve, which make installation to and removal from the shaft easier, particularly with large bearing.

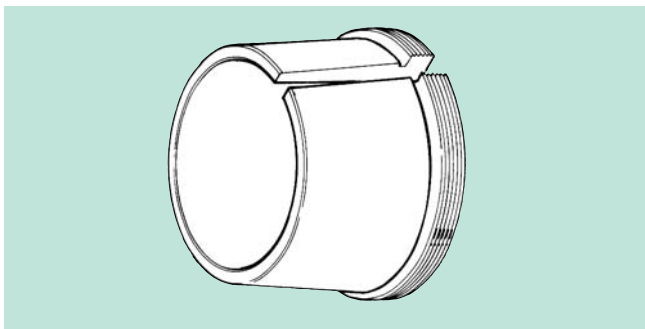

Withdrawal Sleeves

Withdrawal sleeves are used to mount tapered bore bearings on shafts.

Withdrawal sleeve nuts are used when removing bearing from shafts.

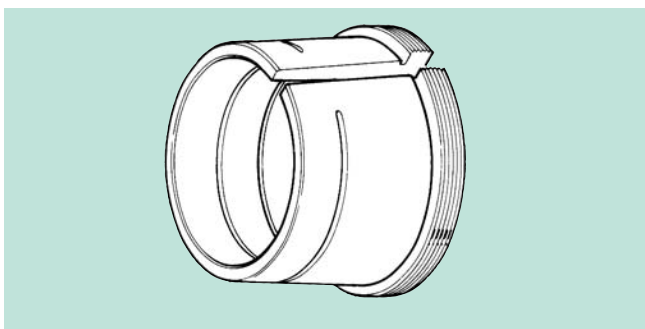

Hydraulic Withdrawal Sleeves

Hydraulic withdrawal sleeves feature an oil inlet and oil groove in the sleeve, which make mounting to the shaft and disassembly easier, particularly with large bearings.

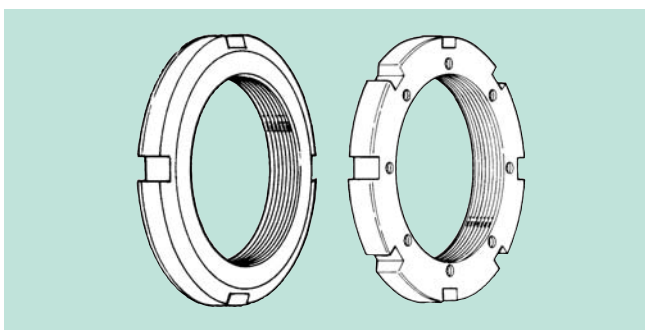

Locknuts, Nuts

Locknuts are used with adapters, withdrawal sleeves and shafts.

Nuts are used with withdrawal sleeves and shafts.

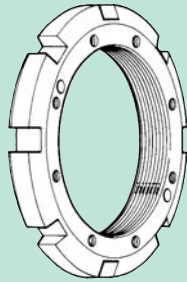

Hydraulic Sleeve Nuts

Hydraulic sleeve nuts feature threaded bolt holes for mounting and withdrawal, and holes for passing through hydraulic hoses.

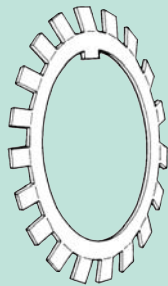

Lockwashers

Lockwashers are used to stop nuts from rotating.

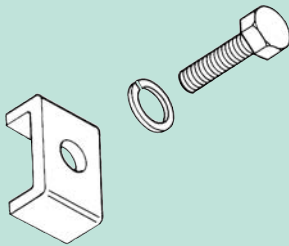

Lockplates

Lockplates are used to stop large nuts from rotating.

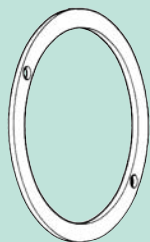

Protective Plates

Protective plates are inserted between the hydraulic sleeve and hydraulic sleeve nut during installation, and protects the sleeve from damage.

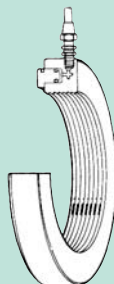

Hydraulic Nuts

(Mounting & Dismounting Tools for Rolling Bearings)

Using hydraulic nuts for mounting and dismounting bearings prevents excessive force being applied, so as to avoid damage to shafts and bearings. The force applied is also uniform for more efficient work.

2. Details of Special Hydraulic Sleeve

Hydraulic Adapters

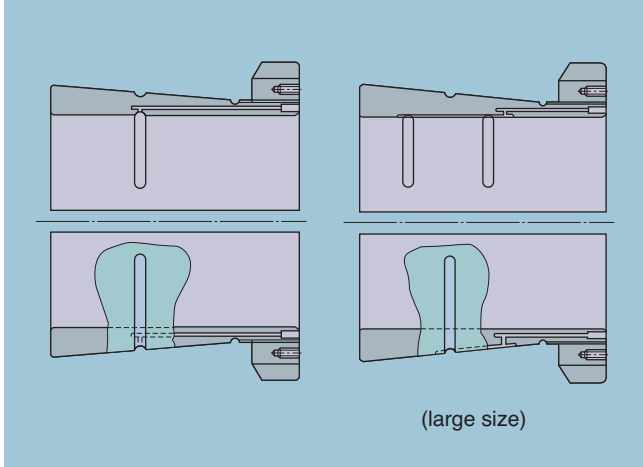

Fig. 1 HFW type

Features an oil groove added to the bore surface of the standard type hydraulic adapter sleeve to suit applications where movement is required between the shaft and adapter.

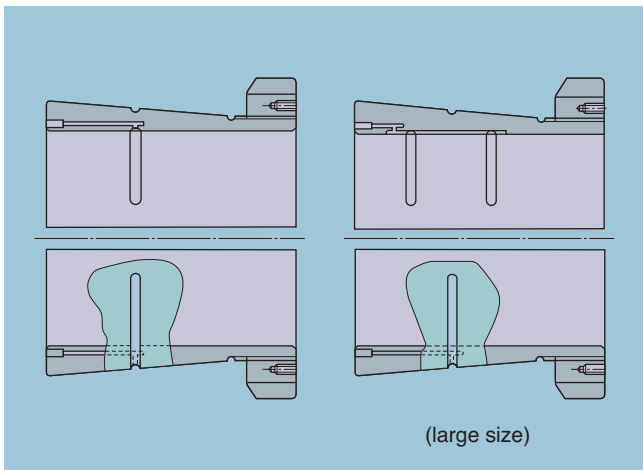

Fig. 2 HBW type

Similar to the HFW type adapter but with the oil inlet on the large side of the adapter sleeve.

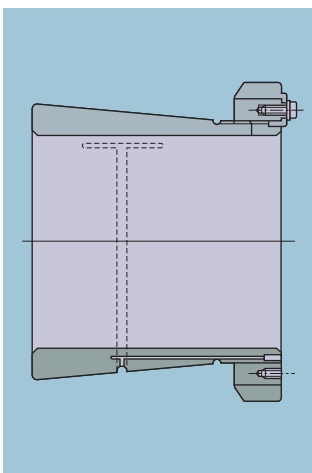

Fig. 3 HFT type

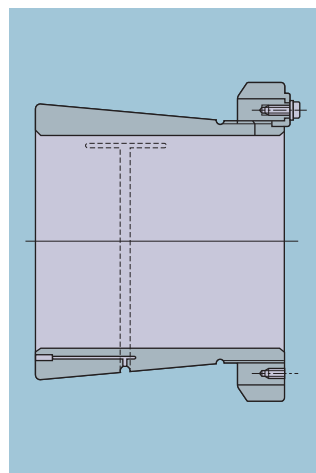

Fig. 4 HBT type

Features an oil groove added to the hydraulic adapter sleeve in an axial direction, which makes installation and removal of bearings even easier.

The HFT type features the HBT type oil inlet added to the large side of the adapter sleeve.

Details of Special Hydraulic Sleeve

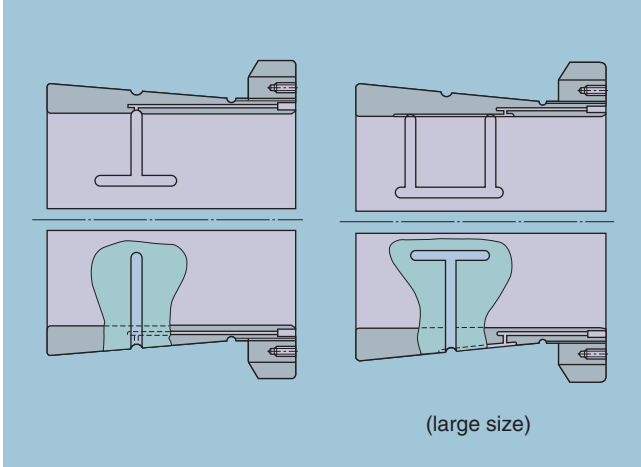

Fig. 5 HFWT type

Feature the HFW type with oil groove added in the axial direction.

Hydraulic Withdrawal Sleeves

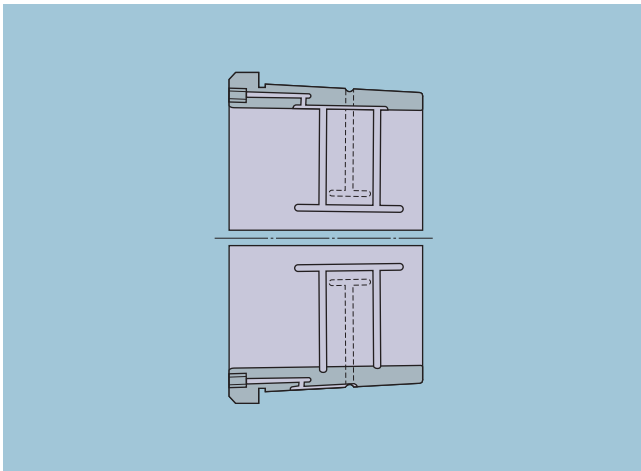

Fig. 6 HT type

Features an oil groove added to the hydraulic withdrawal sleeve in an axial direction, which makes installation and removal of bearings even easier.



3. Dimensions

Contents

	Page
[1] Adapters	
H30, HE30, H30·HF, H30·HB	8
H31, HE31, H31·HF, H31·HB	10
H2, HE2, HS2	12
H32, H32·HF, H32·HB	14
H3, HE3, HS3	16
H23, HE23, HS23, H23·HF, H23·HB	18
H39, H39·HF, H39·HB	20
[2] Withdrawal Sleeves	
AH(X,Y)30, AH(X,Y)30·H	22
AH(X,Y)31, AH(X,Y)31·H	24
AH(Y)2	26
AH(Y)22, AH(Y)22·H	27
AH(X,Y)32, AH(X,Y)32·H	28
AH(X,Y)3	30
AH(X,Y)23, AH(X,Y)23·H	31
AH(X)240, AH(X)240·H	33
AH241, AH241·H	34
AH39, AH39·H	35
[3] Locknuts, Nuts	
AN, AN·SP, AN·SPB	36
ANL, ANL·SP, ANL·SPB	42
HN	44
HNL	45
[4] Lockwashers	
AW	46
AWL	48
[5] Lockplates	
AL, ALL	49
[6] Hydraulic Nuts	
HPN	50
[7] Protective Plates	
ANP	52

Adapters & Hydraulic Adapters

Adapters

Series

H30

HE30

H30··HF (Hydraulic)

H30··HB (Hydraulic)

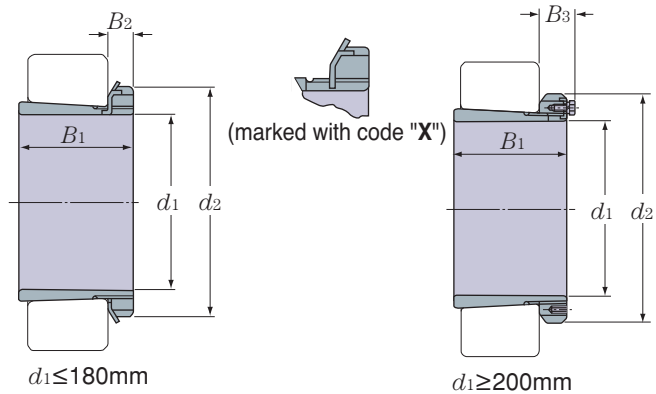

Taper 1:12

Part numbers		Dimensions mm											
H	HE	Sleeve bore diameter d_1		B_2	B_3	d_2	B_1	HF Type			HB Type		
		H	HE					d_s	e	t	d_s	e	t
H3024X	HE3024X	110	107.950(4 $\frac{1}{4}$)	22	—	145	72	—	—	—	—	—	—
H3026	HE3026	115	114.300(4 $\frac{1}{2}$)	23	—	155	80	—	—	—	—	—	—
H3028	HE3028	125	127.000(5)	24	—	165	82	—	—	—	—	—	—
H3030	HE3030	135	133.350(5 $\frac{1}{4}$)	26	—	180	87	—	—	—	—	—	—
H3032	HE3032	140	139.700(5 $\frac{1}{2}$)	28	—	190	93	—	—	—	—	—	—
H3034	HE3034	150	152.400(6)	29	—	200	101	—	—	—	—	—	—
H3036	HE3036	160	165.100(6 $\frac{1}{2}$)	30	—	210	109	—	—	—	—	—	—
H3038	HE3038	170	171.450(6 $\frac{3}{4}$)	31	—	220	112	—	—	—	—	—	—
H3040	HE3040	180	177.800(7)	32	—	240	120	—	—	—	—	—	—
H3044	—	200	—	—	41	260	126	M6	4.2	9	M6	5	9
H3048	—	220	—	—	46	290	133	M6	4.2	9	M6	5	9
H3052	—	240	—	—	46	310	145	M6	4.2	9	M6	5	9
H3056	—	260	—	—	50	330	152	M6	4.2	9	M6	5	9
H3060	—	280	—	—	54	360	168	M6	4.2	9	M6	5	9
H3064	—	300	—	—	55	380	171	M6	3.5	9	M6	5	9
H3068	—	320	—	—	58	400	187	M6	3.5	9	M6	5	9
H3072	—	340	—	—	58	420	188	M6	3.5	9	M8	6.5	12
H3076	—	360	—	—	62	450	193	M6	3.5	9	M8	6.5	12
H3080	—	380	—	—	66	470	210	M6	3.5	9	M8	6.5	12
H3084	—	400	—	—	66	490	212	M6	3.5	9	M8	6.5	12
H3088	—	410	—	—	77	520	228	M8	6.5	12	M8	8	12
H3092	—	430	—	—	77	540	234	M8	6.5	12	M8	8	12
H3096	—	450	—	—	77	560	237	M8	6.5	12	M8	8	12
H30/500	—	470	—	—	85	580	247	M8	6.5	12	M8	8	12

Note : 1) Adapter sleeves with the code "X" appended after the adapter number indicate a narrow slit type adapter sleeves which use washers with straight inner tabs.

2) The part number for hydraulic adapters has the suffix at the end. E.g. **H3044HF**

Adapters & Hydraulic Adapters

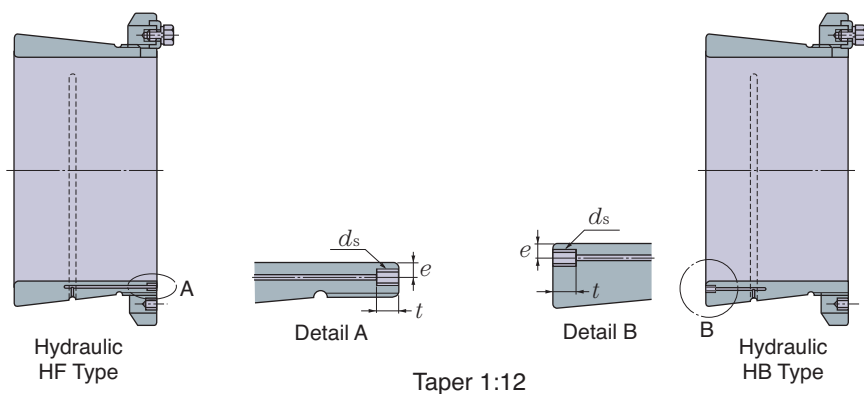

Mass kg (approx.)	Applicable components			
	Adapter sleeve ①	Locknut ②	Lockwasher	Lockplate
1.93	A3024X	ANL24	AWL24X	—
2.85	A3026	ANL26	AWL26	—
3.16	A3028	ANL28	AWL28	—
3.89	A3030	ANL30	AWL30	—
5.21	A3032	ANL32	AWL32	—
5.99	A3034	ANL34	AWL34	—
6.83	A3036	ANL36	AWL36	—
7.45	A3038	ANL38	AWL38	—
9.19	A3040	ANL40	AWL40	—
10.3	A3044	ANL44	—	ALL44
13.2	A3048	ANL48	—	ALL48
15.3	A3052	ANL52	—	ALL48
17.7	A3056	ANL56	—	ALL56
22.8	A3060	ANL60	—	ALL60
24.6	A3064	ANL64	—	ALL64
28.7	A3068	ANL68	—	ALL64
30.5	A3072	ANL72	—	ALL72
35.8	A3076	ANL76	—	ALL76
41.3	A3080	ANL80	—	ALL76
43.7	A3084	ANL84	—	ALL84
65.2	A3088	ANL88	—	ALL88
69.5	A3092	ANL92	—	ALL88
73.3	A3096	ANL96	—	ALL96
81.8	A30/500	ANL100	—	ALL96

① The part number corresponding to H series adapter. For HE30 series adapters, the adapter sleeve part number prefix code is AE.

② For hydraulic adapters, hydraulic sleeve nuts can also be used for mounting bearings (see Fig. 21 on P59).

Adapters & Hydraulic Adapters

Adapters

Series

H31

HE31

H31 ··HF (Hydraulic)

H31 ··HB (Hydraulic)

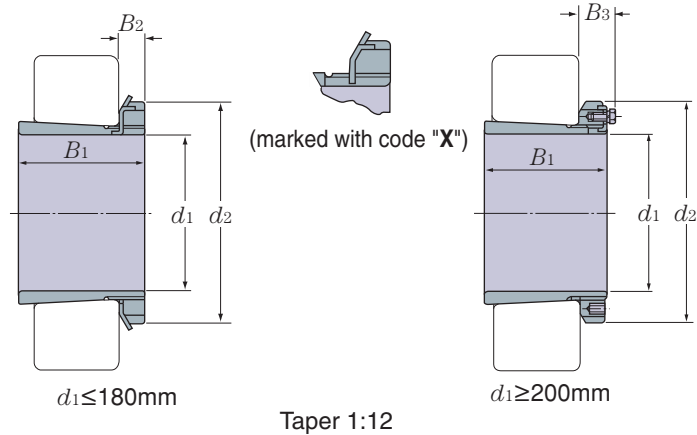

Prat numbers		Dimensions mm												
H	HE	Sleeve bore diameter d_1		B_2	B_3	d_2	B_1	HF Type			HB Type			
		H	HE					d_s	e	t	d_s	e	t	
H3120X	—	90	—	20	—	130	76	—	—	—	—	—	—	—
H3121X	—	95	—	20	—	140	80	—	—	—	—	—	—	—
H3122X	HE3122X	100	101.600(4)	21	—	145	81	—	—	—	—	—	—	—
H3124X	HE3124X	110	107.950(4 $\frac{1}{4}$)	22	—	155	88	—	—	—	—	—	—	—
H3126	HE3126	115	114.300(4 $\frac{1}{2}$)	23	—	165	92	—	—	—	—	—	—	—
H3128	HE3128	125	127.000(5)	24	—	180	97	—	—	—	—	—	—	—
H3130	HE3130	135	133.350(5 $\frac{1}{4}$)	26	—	195	111	—	—	—	—	—	—	—
H3132	HE3132	140	139.700(5 $\frac{1}{2}$)	28	—	210	119	—	—	—	—	—	—	—
H3134	HE3134	150	152.400(6)	29	—	220	122	—	—	—	—	—	—	—
H3136	HE3136	160	165.100(6 $\frac{1}{2}$)	30	—	230	131	—	—	—	—	—	—	—
H3138	HE3138	170	171.450(6 $\frac{3}{4}$)	31	—	240	141	—	—	—	—	—	—	—
H3140	HE3140	180	177.800(7)	32	—	250	150	—	—	—	—	—	—	—
H3144	—	200	—	—	44	280	158	M6	4.2	9	M6	5	9	—
H3148	—	220	—	—	46	300	169	M6	4.2	9	M6	5	9	—
H3152	—	240	—	—	49	330	187	M6	4.2	9	M6	5	9	—
H3156	—	260	—	—	51	350	192	M6	4.2	9	M6	5	9	—
H3160	—	280	—	—	53	380	208	M6	4.2	9	M6	5.5	9	—
H3164	—	300	—	—	56	400	226	M6	3.5	9	M6	5.5	9	—
H3168	—	320	—	—	72	440	254	M6	3.5	9	M6	5.5	9	—
H3172	—	340	—	—	75	460	259	M6	3.5	9	M8	6.5	12	—
H3176	—	360	—	—	77	490	264	M6	3.5	9	M8	6.5	12	—
H3180	—	380	—	—	82	520	272	M6	3.5	9	M8	6.5	12	—
H3184	—	400	—	—	90	540	304	M6	3.5	9	M8	6.5	12	—
H3188	—	410	—	—	90	560	307	M8	6.5	12	M8	6.5	12	—
H3192	—	430	—	—	95	580	326	M8	6.5	12	Rc $\frac{1}{8}$	8	15	—
H3196	—	450	—	—	95	620	335	M8	6.5	12	Rc $\frac{1}{8}$	8	15	—
H31/500	—	470	—	—	100	630	356	M8	6.5	12	Rc $\frac{1}{8}$	8	15	—

Note : 1) Adapter sleeves with the code "X" appended after the adapter number indicate a narrow slit type adapter sleeves which use washers with straight inner tabs.

2) The part number for hydraulic adapters has the suffix at the end. E.g. **H3144HF**

Adapters & Hydraulic Adapters

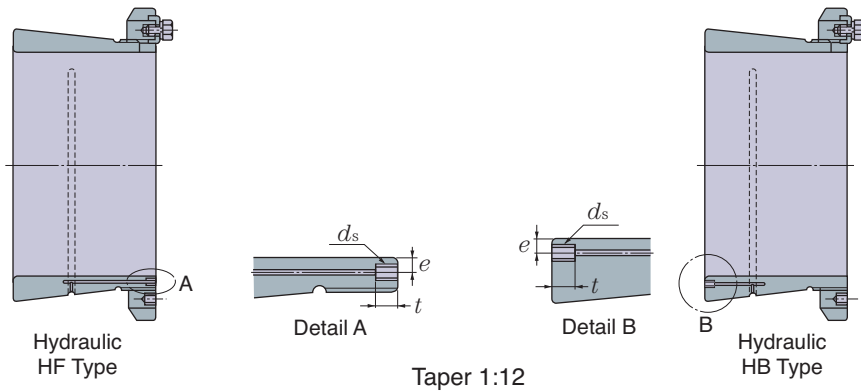

Mass kg (approx.)	Applicable components			
	Adapter ^① sleeve	Locknut ^②	Lockwasher	Lockplate
1.78	A3120X	AN20	AW20X	—
2.10	A3121X	AN21	AW21X	—
2.25	A3122X	AN22	AW22X	—
2.64	A3124X	AN24	AW24X	—
3.66	A3126	AN26	AW26	—
4.34	A3128	AN28	AW28	—
5.52	A3130	AN30	AW30	—
7.67	A3132	AN32	AW32	—
8.38	A3134	AN34	AW34	—
9.5	A3136	AN36	AW36	—
10.8	A3138	AN38	AW38	—
12.1	A3140	AN40	AW40	—
14.7	A3144	AN44	—	AL44
17.3	A3148	AN48	—	AL44
22	A3152	AN52	—	AL52
24.5	A3156	AN56	—	AL52
30.2	A3160	AN60	—	AL60
34.9	A3164	AN64	—	AL64
49.5	A3168	AN68	—	AL68
54.2	A3172	AN72	—	AL68
61.7	A3176	AN76	—	AL76
70.6	A3180	AN80	—	AL80
84.2	A3184	AN84	—	AL80
104	A3188	AN88	—	AL88
116	A3192	AN92	—	AL88
133	A3196	AN96	—	AL96
143	A31/500	AN100	—	AL100

① The part number corresponding to H series adapter. For HE31 series adapters, the adapter sleeve part number prefix code is AE.

② For hydraulic adapters, hydraulic sleeve nuts can also be used for mounting bearings (see Fig. 21 on P59).

Adapters

Adapters

Series

H2
HE2
HS2

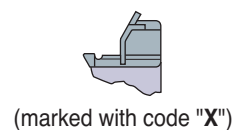
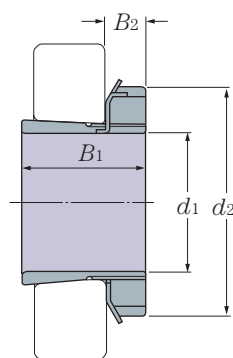

Taper 1:12

Part numbers			Dimensions mm						Mass kg (approx.)
			Sleeve bore diameter d_1			B_2	d_2	B_1	
H	HE	HS	H	HE	HS				
H205X	HE205	—	20	19.050($\frac{3}{4}$)	—	8	38	26	0.070
H206X	HE206X	HS206	25	25.400(1)	22.225($\frac{7}{8}$)	8	45	27	0.099
H207X	—	HS207	30	—	28.575($1\frac{1}{8}$)	9	52	29	0.125
H208X	HE208X	HS208X	35	31.750($1\frac{1}{4}$)	34.925($1\frac{3}{8}$)	10	58	31	0.174
H209X	HE209X	HS209X	40	38.100($1\frac{1}{2}$)	41.275($1\frac{5}{8}$)	11	65	33	0.227
H210X	HE210X	HS210	45	44.450($1\frac{3}{4}$)	41.275($1\frac{5}{8}$)	12	70	35	0.274
H211X	HE211XY	HS211	50	50.800(2)	47.625($1\frac{7}{8}$)	12	75	37	0.308
H212X	—	HS212	55	—	53.975($2\frac{1}{8}$)	13	80	38	0.346
H213X	HE213X	HS213X	60	57.150($2\frac{1}{4}$)	60.325($2\frac{3}{8}$)	14	85	40	0.401
H214	—	—	60	—	—	14	92	41	0.593
H215X	HE215X	—	65	63.500($2\frac{1}{2}$)	—	15	98	43	0.707
H216X	HE216X	—	70	69.850($2\frac{3}{4}$)	—	17	105	46	0.882
H217X	HE217X	—	75	76.200(3)	—	18	110	50	1.02
H218X	—	—	80	—	—	18	120	52	1.19
H219X	HE219X	—	85	82.550($3\frac{1}{4}$)	—	19	125	55	1.37
H220X	HE220X	—	90	88.900($3\frac{1}{2}$)	—	20	130	58	1.49
H222X	HE222X	—	100	101.600(4)	—	21	145	63	1.93

Note : 1) Adapter sleeves with the code "X" appended after the adapter number indicate a narrow slit type adapter sleeves which use washers with straight inner tabs.

2) Part number **HE211XY** uses a different thread pitch than standard due to the wall thickness of the adapter sleeve thread, and has the suffix code **Y** for identification purposes.

3) Part number **H214** indicates that it does not meet JIS B 1522 standards.

Adapters

Applicable components		
Adapter sleeve ❶	Locknut	Lockwasher
A205X	AN05	AW05X
A206X	AN06	AW06X
A207X	AN07	AW07X
A208X	AN08	AW08X
A209X	AN09	AW09X
A210X	AN10	AW10X
A211X	AN11	AW11X
A212X	AN12	AW12X
A213X	AN13	AW13X
A214	AN14	AW14
A215X	AN15	AW15X
A216X	AN16	AW16X
A217X	AN17	AW17X
A218X	AN18	AW18X
A219X	AN19	AW19X
A220X	AN20	AW20X
A222X	AN22	AW22X

❶ The part number corresponding to H series adapter. For HE2 and HS2 series adapters, the adapter sleeve part number prefix code is AE and AS.

Adapters & Hydraulic Adapters

Adapters

Series

H32

H32 · · HF (Hydraulic)

H32 · · HB (Hydraulic)

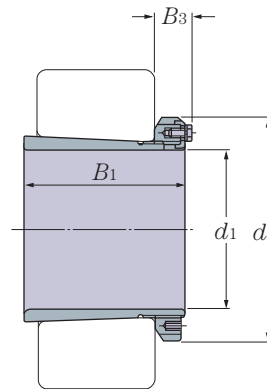

Taper 1:12

Part numbers	Dimensions mm									
	Sleeve bore diameter d_1	B_3	d_2	B_1	HF Type			HB Type		
					d_s	e	t	d_s	e	t
H3260	280	53	380	240	M6	4.2	9	M8	6.5	12
H3264	300	56	400	258	M6	3.5	9	M8	6.5	12
H3268	320	72	440	288	M6	3.5	9	M8	6.5	12
H3272	340	75	460	299	M6	3.5	9	M8	8	12
H3276	360	77	490	310	M6	3.5	9	M8	8	12
H3280	380	82	520	328	M6	3.5	9	M8	8	12

Note : The part number for hydraulic adapters has the suffix at the end. E.g. **H3260HF**

Adapters & Hydraulic Adapters

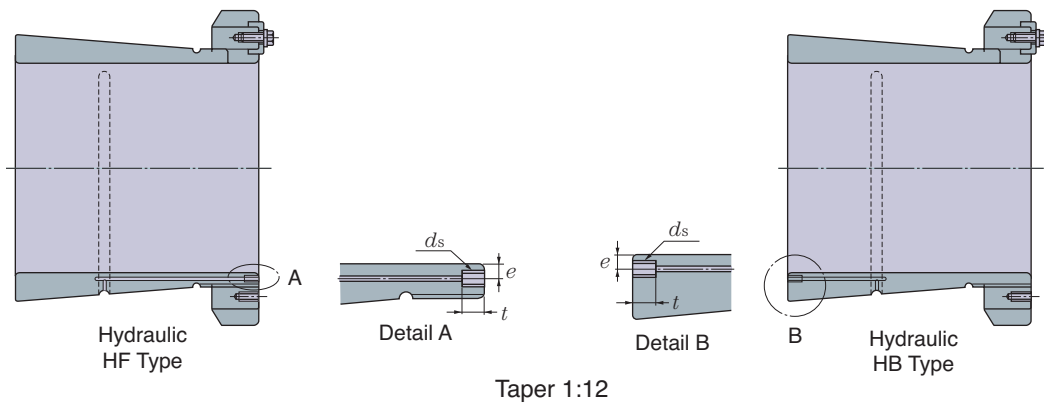

Mass kg (approx.)	Applicable components		
	Adapter ^① sleeve	Locknut ^②	Lockwasher
34.1	A3260	AN60	AL60
39.3	A3264	AN64	AL64
54.6	A3268	AN68	AL68
60.2	A3272	AN72	AL68
69.6	A3276	AN76	AL76
81.0	A3280	AN80	AL80

^① The part number corresponding to H series adapter.

^② For hydraulic adapters, hydraulic sleeve nuts can also be used for mounting bearings (see Fig. 21 on P59).

Adapters

Adapters

Series

H3

HE3

HS3

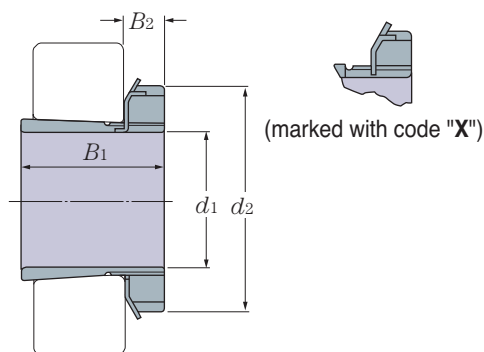

Taper 1:12

Part numbers			Dimensions mm						Mass kg (approx.)
H	HE	HS	Sleeve bore diameter d_1			B_2	d_2	B_1	
			H	HE	HS				
H305X	HE305	—	20	19.050 ($\frac{3}{4}$)	—	8	38	29	0.075
H306X	HE306X	HS306	25	25.400 (1)	22.225 ($\frac{7}{8}$)	8	45	31	0.109
H307X	—	HS307	30	—	28.575 ($1\frac{1}{8}$)	9	52	35	0.142
H308X	HE308X	HS308X	35	31.750 ($1\frac{1}{4}$)	34.925 ($1\frac{3}{8}$)	10	58	36	0.189
H309X	HE309X	HS309X	40	38.100 ($1\frac{1}{2}$)	41.275 ($1\frac{5}{8}$)	11	65	39	0.248
H310X	HE310X	HS310	45	44.450 ($1\frac{3}{4}$)	41.275 ($1\frac{5}{8}$)	12	70	42	0.303
H311X	HE311XY	HS311	50	50.800 (2)	47.625 ($1\frac{7}{8}$)	12	75	45	0.345
H312X	—	HS312	55	—	53.975 ($2\frac{1}{8}$)	13	80	47	0.394
H313X	HE313X	HS313X	60	57.150 ($2\frac{1}{4}$)	60.325 ($2\frac{3}{8}$)	14	85	50	0.458
H314	—	—	60	—	—	14	92	52	0.723
H315X	HE315X	—	65	63.500 ($2\frac{1}{2}$)	—	15	98	55	0.831
H316X	HE316X	—	70	69.850 ($2\frac{3}{4}$)	—	17	105	59	1.03
H317X	HE317X	—	75	76.200 (3)	—	18	110	63	1.18
H318X	—	—	80	—	—	18	120	65	1.37
H319X	HE319X	—	85	82.550 ($3\frac{1}{4}$)	—	19	125	68	1.56
H320X	HE320X	—	90	88.900 ($3\frac{1}{2}$)	—	20	130	71	1.69
H322X	HE322X	—	100	101.600 (4)	—	21	145	77	2.18

Note : 1) Adapter sleeves with the code "X" appended after the adapter number indicate a narrow slit type adapter sleeves which use washers with straight inner tabs.
 2) Part number **HE311XY** uses a different thread pitch than standard due to the wall thickness of the adapter sleeve thread, and has the suffix code **Y** for identification purposes.

Adapters

Applicable components		
Adapter sleeve ❶	Locknut	Lockwasher
A305X	AN05	AW05X
A306X	AN06	AW06X
A307X	AN07	AW07X
A308X	AN08	AW08X
A309X	AN09	AW09X
A310X	AN10	AW10X
A311X	AN11	AW11X
A312X	AN12	AW12X
A313X	AN13	AW13X
A314	AN14	AW14
A315X	AN15	AW15X
A316X	AN16	AW16X
A317X	AN17	AW17X
A318X	AN18	AW18X
A319X	AN19	AW19X
A320X	AN20	AW20X
A322X	AN22	AW22X

❶ The part number corresponding to H series adapter. For HE23 and HS23 series adapters, the adapter sleeve part number prefix code is AE and AS.

Adapters & Hydraulic Adapters

Adapters

Series

H23

HE23

HS23

H23··HF (Hydraulic)

H23··HB (Hydraulic)

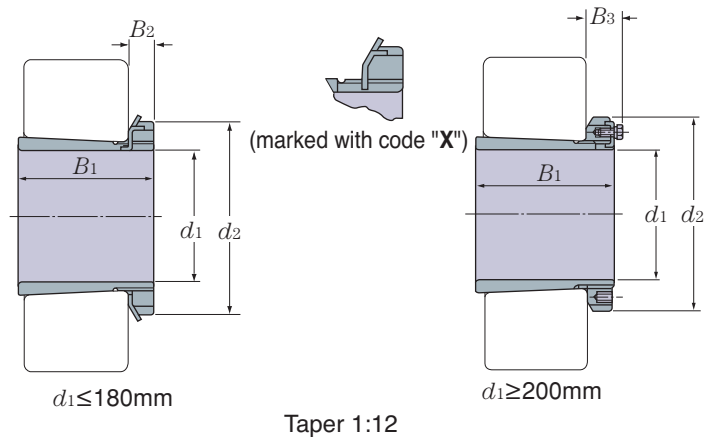

Part numbers			Dimensions mm						
H	HE	HS	Sleeve bore diameter d_1			B_2	B_3	d_2	B_1
			H	HE	HS				
H2305X	HE2305	—	20	19.050 ($\frac{3}{4}$)	—	8	—	38	35
H2306X	HE2306X	HS2306	25	25.400 (1)	22.225 ($\frac{7}{8}$)	8	—	45	38
H2307X	—	HS2307	30	—	28.575 ($1\frac{1}{8}$)	9	—	52	43
H2308X	HE2308X	HS2308X	35	31.750 ($1\frac{1}{4}$)	34.925 ($1\frac{3}{8}$)	10	—	58	46
H2309X	HE2309X	HS2309X	40	38.100 ($1\frac{1}{2}$)	41.275 ($1\frac{5}{8}$)	11	—	65	50
H2310X	HE2310X	HS2310	45	44.450 ($1\frac{3}{4}$)	41.275 ($1\frac{5}{8}$)	12	—	70	55
H2311X	HE2311XY	HS2311	50	50.800 (2)	47.625 ($1\frac{7}{8}$)	12	—	75	59
H2312X	—	HS2312	55	—	53.975 ($2\frac{1}{8}$)	13	—	80	62
H2313X	HE2313X	HS2313X	60	57.150 ($2\frac{1}{4}$)	60.325 ($2\frac{3}{8}$)	14	—	85	65
H2314	—	—	60	—	—	14	—	92	68
H2315X	HE2315X	—	65	63.500 ($2\frac{1}{2}$)	—	15	—	98	73
H2316X	HE2316X	—	70	69.850 ($2\frac{3}{4}$)	—	17	—	105	78
H2317X	HE2317X	—	75	76.200 (3)	—	18	—	110	82
H2318X	—	—	80	—	—	18	—	120	86
H2319X	HE2319X	—	85	82.550 ($3\frac{1}{4}$)	—	19	—	125	90
H2320X	HE2320X	—	90	88.900 ($3\frac{1}{2}$)	—	20	—	130	97
H2322X	HE2322X	—	100	101.600 (4)	—	21	—	145	105
H2324X	HE2324X	—	110	107.950 ($4\frac{1}{4}$)	—	22	—	155	112
H2326	HE2326	—	115	114.300 ($4\frac{1}{2}$)	—	23	—	165	121
H2328	HE2328	—	125	127.000 (5)	—	24	—	180	131
H2330	HE2330	—	135	133.350 ($5\frac{1}{4}$)	—	26	—	195	139
H2332	HE2332	—	140	139.700 ($5\frac{1}{2}$)	—	28	—	210	147
H2334	HE2334	—	150	152.400 (6)	—	29	—	220	154
H2336	HE2336	—	160	165.100 ($6\frac{1}{2}$)	—	30	—	230	161
H2338	HE2338	—	170	171.450 ($6.3/4$)	—	31	—	240	169
H2340	HE2340	—	180	177.800 (7)	—	32	—	250	176
H2344	—	—	200	—	—	—	44	280	183
H2348	—	—	220	—	—	—	46	300	196
H2352	—	—	240	—	—	—	49	330	208
H2356	—	—	260	—	—	—	51	350	221

Note : 1) Adapter sleeves with the code "X" appended after the adapter number indicate a narrow slit type adapter sleeves which use washers with straight inner tabs.

2) Part number **HE2311XY** uses a different thread pitch than standard due to the wall thickness of the adapter sleeve thread, and has the suffix code **Y** for identification purposes.

3) The part number for hydraulic adapters has the suffix at the end. E.g. **H2344HF**

Adapters & Hydraulic Adapters

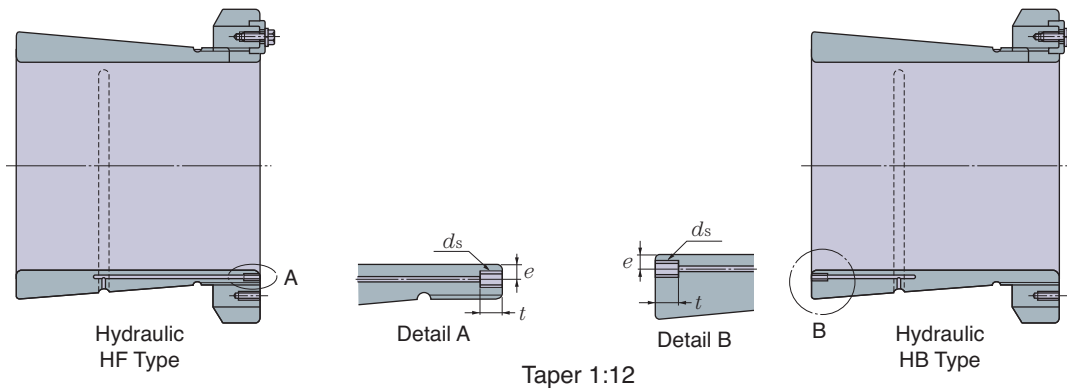

Dimensions mm						Mass kg (approx.)	Applicable components			
HF Type			HB Type				Adapter ^① sleeve	Locknut ^②	Washer	Lockwasher
d_s	e	t	d_s	e	t					
—	—	—	—	—	—	0.087	A2305X	AN05	AW05X	—
—	—	—	—	—	—	0.126	A2306X	AN06	AW06X	—
—	—	—	—	—	—	0.165	A2307X	AN07	AW07X	—
—	—	—	—	—	—	0.224	A2308X	AN08	AW08X	—
—	—	—	—	—	—	0.280	A2309X	AN09	AW09X	—
—	—	—	—	—	—	0.362	A2310X	AN10	AW10X	—
—	—	—	—	—	—	0.420	A2311X	AN11	AW11X	—
—	—	—	—	—	—	0.481	A2312X	AN12	AW12X	—
—	—	—	—	—	—	0.557	A2313X	AN13	AW13X	—
—	—	—	—	—	—	0.897	A2314	AN14	AW14	—
—	—	—	—	—	—	1.05	A2315X	AN15	AW15X	—
—	—	—	—	—	—	1.28	A2316X	AN16	AW16X	—
—	—	—	—	—	—	1.45	A2317X	AN17	AW17X	—
—	—	—	—	—	—	1.69	A2318X	AN18	AW18X	—
—	—	—	—	—	—	1.92	A2319X	AN19	AW19X	—
—	—	—	—	—	—	2.15	A2320X	AN20	AW20X	—
—	—	—	—	—	—	2.74	A2322X	AN22	AW22X	—
—	—	—	—	—	—	3.19	A2324X	AN24	AW24X	—
—	—	—	—	—	—	4.60	A2326	AN26	AW26	—
—	—	—	—	—	—	5.55	A2328	AN28	AW28	—
—	—	—	—	—	—	6.63	A2330	AN30	AW30	—
—	—	—	—	—	—	9.14	A2332	AN32	AW32	—
—	—	—	—	—	—	10.2	A2334	AN34	AW34	—
—	—	—	—	—	—	11.3	A2336	AN36	AW36	—
—	—	—	—	—	—	12.6	A2338	AN38	AW38	—
—	—	—	—	—	—	13.9	A2340	AN40	AW40	—
M6	4.2	9	M6	5	9	16.7	A2344	AN44	—	AL44
M6	4.2	9	M6	5	9	19.7	A2348	AN48	—	AL44
M6	4.2	9	M6	5	9	24.2	A2352	AN52	—	AL52
M6	4.2	9	M6	5	9	27.8	A2356	AN56	—	AL52

① The part number corresponding to H series adapter. For HE23 and HS23 series adapters, the adapter sleeve part number prefix code is AE and AS.

② For hydraulic adapters, hydraulic sleeve nuts can also be used for mounting bearings (see Fig. 21 on P59).

Adapters & Hydraulic Adapters

Adapters

Series

H39

H39··HF (Hydraulic)

H39··HB (Hydraulic)

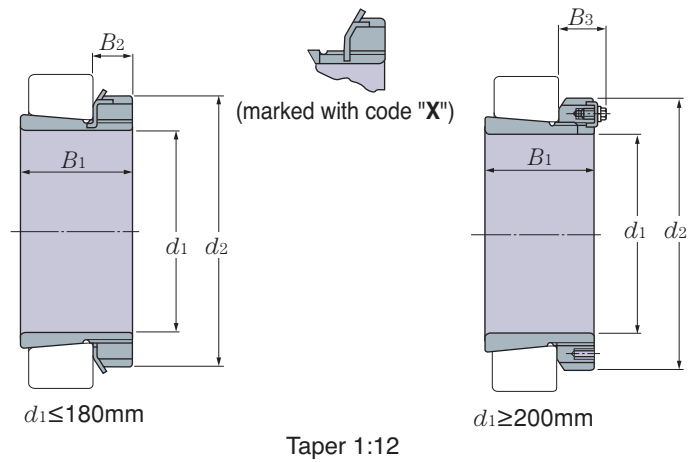

Part numbers	Dimensions mm											
	Sleeve bore diameter d_1	B_2	B_3	d_2	B_1	HF Type			HB Type			
						d_s	e	t	d_s	e	t	
H3924X	110	22	—	145	60	—	—	—	—	—	—	
H3926	115	23	—	155	65	—	—	—	—	—	—	
H3928	125	24	—	165	66	—	—	—	—	—	—	
H3930	135	26	—	180	76	—	—	—	—	—	—	
H3932	140	28	—	190	78	—	—	—	—	—	—	
H3934	150	29	—	200	79	—	—	—	—	—	—	
H3936	160	30	—	210	87	—	—	—	—	—	—	
H3938	170	31	—	220	89	—	—	—	—	—	—	
H3940	180	32	—	240	98	—	—	—	—	—	—	
H3944	200	—	41	260	96	M6	4.2	9	M6	5	9	
H3948	220	—	46	290	101	M6	4.2	9	M6	5	9	
H3952	240	—	46	310	116	M6	4.2	9	M6	5	9	
H3956	260	—	50	330	121	M6	4.2	9	M6	5	9	
H3960	280	—	54	360	140	M6	4.2	9	M6	5	9	
H3964	300	—	55	380	140	M6	3.5	9	M6	5	9	
H3968	320	—	58	400	144	M6	3.5	9	M6	5	9	
H3972	340	—	58	420	144	M6	3.5	9	M6	5	9	
H3976	360	—	62	450	164	M6	3.5	9	M6	5	9	
H3980	380	—	66	470	168	M6	3.5	9	M6	5	9	
H3984	400	—	66	490	168	M6	3.5	9	M6	5	9	
H3988	410	—	77	520	189	M8	6.5	12	M8	6.5	12	
H3992	430	—	77	540	189	M8	6.5	12	M8	6.5	12	
H3996	450	—	77	560	200	M8	6.5	12	M8	8	12	

Note : The part number for hydraulic adapters has the suffix at the end. E.g. **H3944HF**

Adapters & Hydraulic Adapters

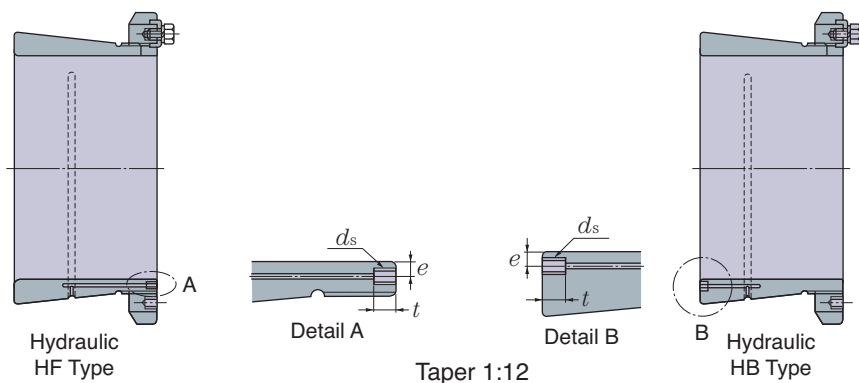

Mass kg (approx.)	Applicable components			
	Adapter ^① sleeve	Locknut ^②	Lockwasher	Lockplate
1.86	A3924X	ANL24	AWL24X	—
2.65	A3926	ANL26	AWL26	—
2.94	A3928	ANL28	AWL28	—
3.85	A3930	ANL30	AWL30	—
4.57	A3932	ANL32	AWL32	—
4.95	A3934	ANL34	AWL34	—
5.7	A3936	ANL36	AWL36	—
6.19	A3938	ANL38	AWL38	—
7.89	A3940	ANL40	AWL40	—
8.16	A3944	ANL44	—	ALL44
10.7	A3948	ANL48	—	ALL48
12.8	A3952	ANL52	—	ALL48
14.8	A3956	ANL56	—	ALL56
19.8	A3960	ANL60	—	ALL60
21	A3964	ANL64	—	ALL64
23.5	A3968	ANL68	—	ALL64
24.5	A3972	ANL72	—	ALL72
31.5	A3976	ANL76	—	ALL76
35	A3980	ANL80	—	ALL76
36.6	A3984	ANL84	—	ALL84
57.3	A3988	ANL88	—	ALL88
59.9	A3992	ANL92	—	ALL88
64.9	A3996	ANL96	—	ALL96

① The part number corresponding to H series adapter.

② For hydraulic adapters, hydraulic sleeve nuts can also be used for mounting bearings (see Fig. 21 on P59).

Withdrawal Sleeves & Hydraulic Withdrawal Sleeves

Withdrawal Sleeves

Series

AH(X,Y)30

AH(X,Y)30·H (Hydraulic)

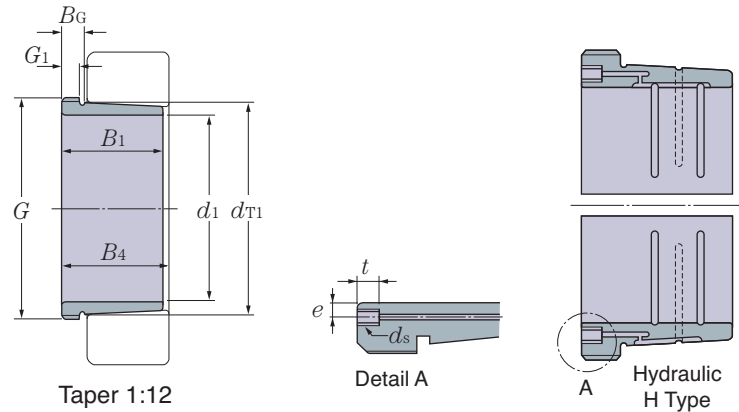

Part numbers	Thread ❶	Dimensions mm						H Type			Mass kg (approx.)	G ₁	Applicable ^❺ Nut numbers
		d ₁	B ₁	B ₄ ^❷	d _{T1} ^❸	B _G ^❹	d _s	e	t				
AHX3024	M130×2	115	60	64	124.00	16	—	—	—	0.750	13	AN26	
AHX3026	M140×2	125	67	71	134.50	17	—	—	—	0.930	14	AN28	
AHX3028	M150×2	135	68	73	144.67	17	—	—	—	1.01	14	AN30	
AHX3030	M160×3	145	72	77	154.92	18	—	—	—	1.15	15	AN32	
AH3032	M170×3	150	77	82	165.25	19	—	—	—	2.06	16	AN34	
AH3034	M180×3	160	85	90	175.83	20	—	—	—	2.43	17	AN36	
AH3036	M190×3	170	92	98	186.08	25	—	—	—	2.81	17	AN38	
AHY3038	M200×3	180	96	102	196.50	24	—	—	—	3.32	18	AN40	
AH3038	Tr205×4	180	96	102	196.50	24	—	—	—	3.32	18	HNL41	
AHY3040	Tr210×4	190	102	108	206.92	25	—	—	—	3.80	19	HN42	
AH3040	Tr215×4	190	102	108	206.92	25	—	—	—	3.80	19	HNL43	
AHY3044	Tr230×4	200	111	117	227.58	26	—	—	—	7.40	20	HN46	
AH3044	Tr235×4	200	111	117	227.58	26	Rc ¹ / ₈	8.5	15	7.40	20	HNL47	
AH3048	Tr260×4	220	116	123	248.00	27	Rc ¹ / ₈	8.5	15	8.75	21	HNL52	
AH3052	Tr280×4	240	128	135	268.83	29	Rc ¹ / ₈	8.5	15	10.7	23	HNL56	
AH3056	Tr300×4	260	131	139	289.08	30	Rc ¹ / ₈	8.5	15	12.0	24	HNL60	
AH3060	Tr320×5	280	145	153	310.08	32	Rc ¹ / ₈	8.5	15	14.4	26	HNL64	
AHY3064	Tr340×5	300	149	157	330.33	33	Rc ¹ / ₈	8.5	15	16.0	27	HNL68	
AH3064	Tr345×5	300	149	157	330.33	33	Rc ¹ / ₈	8.5	15	16.0	27	HNL69	
AHY3068	Tr360×5	320	162	171	351.42	34	Rc ¹ / ₈	8.5	15	19.5	28	HNL72	
AH3068	Tr365×5	320	162	171	351.42	34	Rc ¹ / ₈	8.5	15	19.5	28	HNL73	
AHY3072	Tr380×5	340	167	176	371.67	36	Rc ¹ / ₈	8.5	15	21.0	30	HNL76	
AH3072	Tr385×5	340	167	176	371.67	36	Rc ¹ / ₈	8.5	15	21.0	30	HNL77	
AHY3076	Tr400×5	360	170	180	391.92	37	Rc ¹ / ₈	8.5	15	23.2	31	HNL80	
AH3076	Tr410×5	360	170	180	391.92	37	Rc ¹ / ₈	8.5	15	23.2	31	HNL82	
AHY3080	Tr420×5	380	183	193	412.83	39	Rc ¹ / ₈	8.5	15	27.3	33	HNL84	
AH3080	Tr430×5	380	183	193	412.83	39	Rc ¹ / ₈	8.5	15	27.3	33	HNL86	

❶ Standard thread shapes and dimensions of the part numbers AHX3024 to AHY3038 are as per JIS B0205-1 and JIS B 0205-4 (general purpose metric screw threads). Standard thread shapes and dimensions of the part numbers AH3038 to AHX3096 are as per JIS B 0216 (metric trapezoidal screw threads).

❷ B₄ dimensions indicate reference dimensions before attachment of withdrawal sleeves.

❸ d_{T1} dimensions indicate that it does not meet JIS B 1552 standards.

❹ B_G dimensions indicate that it does not meet JIS B 1552 standards.

❺ Indicates nut to be used at time of disassembly.

Withdrawal Sleeves & Hydraulic Withdrawal Sleeves

Prat numbers	Thread ① <i>G</i>	Dimensions mm								Mass kg (approx.)	<i>G</i> ₁	Applicable ^⑤ Nut numbers
		<i>d</i> ₁	<i>B</i> ₁	<i>B</i> ₄ ^②	<i>d</i> _{T1} ^③	<i>B</i> _G ^④	H Type					
							<i>d</i> _s	<i>e</i>	<i>t</i>			
AHY3084	Tr440×5	400	186	196	433.00	40	Rc $\frac{1}{8}$	8.5	15	29.0	34	HNL88
AH3084	Tr450×5	400	186	196	433.00	40	Rc $\frac{1}{8}$	8.5	15	29.0	34	HNL90
AHY3088	Tr460×5	420	194	205	453.67	41	Rc $\frac{1}{8}$	8.5	15	32.0	35	HNL92
AHX3088	Tr470×5	420	194	205	453.67	41	Rc $\frac{1}{8}$	8.5	15	32.0	35	HNL94
AHY3092	Tr480×5	440	202	213	474.17	43	Rc $\frac{1}{8}$	8.5	15	35.2	37	HNL96
AHX3092	Tr490×5	440	202	213	474.17	43	Rc $\frac{1}{8}$	8.5	15	35.2	37	HNL98
AHY3096	Tr500×5	460	205	217	494.42	44	Rc $\frac{1}{8}$	8.5	15	39.2	38	HNL100
AHX3096	Tr520×6	460	205	217	494.42	44	Rc $\frac{1}{8}$	8.5	15	39.2	38	HNL104

Note : The part number for hydraulic adapters has the suffix at the end. E.g. **AH3044H**

Withdrawal Sleeves & Hydraulic Withdrawal Sleeves

Withdrawal Sleeves

Series

AH(X,Y)31

AH(X,Y)31··H (Hydraulic)

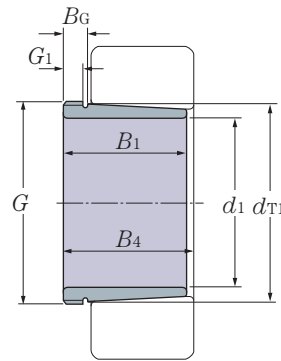

Taper 1:12

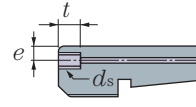

Detail A

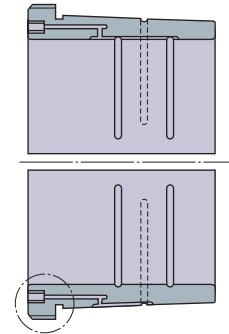

A Hydraulic H Type

Part numbers	Thread ① G	Dimensions mm						H Type			Mass kg (approx.)	G ₁	Applicable ^⑤ Nut numbers
		d ₁	B ₁	B ₄ ^②	d _{T1} ^③	B _G ^④	d _s	e	t				
AH3120	M110×2	95	64	68	104.50	14	—	—	—	0.650	11	AN22	
AH3121	M115×2	100	68	72	109.83	14	—	—	—	0.690	11	AN23	
AHX3122	M120×2	105	68	72	114.83	14	—	—	—	0.760	11	AN24	
AHX3124	M130×2	115	75	79	125.33	15	—	—	—	0.950	12	AN26	
AHX3126	M140×2	125	78	82	135.58	15	—	—	—	1.08	12	AN28	
AHX3128	M150×2	135	83	88	145.92	17	—	—	—	1.28	14	AN30	
AHX3130	M165×3	145	96	101	156.92	18	—	—	—	1.79	15	AN33	
AH3132	M180×3	150	103	108	167.42	19	—	—	—	3.21	16	AN36	
AH3134	M190×3	160	104	109	177.50	19	—	—	—	3.40	16	AN38	
AHY3136	M190×3	170	116	122	188.33	22	—	—	—	4.22	19	AN38	
AH3136	M200×3	170	116	122	188.33	22	—	—	—	4.22	19	AN40	
AHY3138	M200×3	180	125	131	198.75	26	—	—	—	4.89	20	AN40	
AH3138	Tr210×4	180	125	131	198.75	26	—	—	—	4.89	20	HN42	
AH3140	Tr220×4	190	134	140	209.42	27	—	—	—	5.49	21	HN44	
AH3144	Tr240×4	200	145	151	230.17	29	Rc ¹ / ₈	8.5	15	10.4	23	HN48	
AH3148	Tr260×4	220	154	161	250.83	31	Rc ¹ / ₈	8.5	15	12.0	25	HN52	
AHY3152	Tr280×4	240	172	179	272.25	32	Rc ¹ / ₈	8.5	15	16.2	26	HN56	
AH3152	Tr290×4	240	172	179	272.25	32	Rc ¹ / ₈	8.5	15	16.2	26	HN58	
AHY3156	Tr300×4	260	175	183	292.42	34	Rc ¹ / ₈	8.5	15	17.5	28	HN60	
AH3156	Tr310×5	260	175	183	292.42	34	Rc ¹ / ₈	8.5	15	17.5	28	HN62	
AHY3160	Tr320×5	280	192	200	313.67	36	Rc ¹ / ₈	8.5	15	20.8	30	HN64	
AH3160	Tr330×5	280	192	200	313.67	36	Rc ¹ / ₈	8.5	15	20.8	30	HN66	
AHY3164	Tr340×5	300	209	217	335.00	37	Rc ¹ / ₈	8.5	15	24.5	31	HN68	
AH3164	Tr350×5	300	209	217	335.00	37	Rc ¹ / ₈	8.5	15	24.5	31	HN70	
AHY3168	Tr360×5	320	225	234	356.25	39	Rc ¹ / ₈	8.5	15	29	33	HN72	
AH3168	Tr370×5	320	225	234	356.25	39	Rc ¹ / ₈	8.5	15	29	33	HN74	
AHY3172	Tr380×5	340	229	238	376.42	41	Rc ¹ / ₈	8.5	15	33	35	HN76	

① Standard thread shapes and dimensions of the part numbers AHX3120 to AHY3138 are as per JIS B 0205-1 and JIS B 0205-4 (general purpose metric screw threads). Standard thread shapes and dimensions of the part numbers AH3138 to AHX3196 are as per JIS B 0216 (metric trapezoidal screw threads).

② B₄ dimensions indicate reference dimensions before attachment of withdrawal sleeves.

③ d_{T1} dimensions indicate that it does not meet JIS B 1552 standards.

④ B_G dimensions indicate that it does not meet JIS B 1552 standards.

⑤ Indicates nut to be used at time of disassembly.

Withdrawal Sleeves & Hydraulic Withdrawal Sleeves

Part numbers	Thread ① <i>G</i>	Dimensions mm								Mass kg (approx.)	<i>G</i> ₁	Applicable ^⑤ Nut numbers
		<i>d</i> ₁	<i>B</i> ₁	<i>B</i> ₄ ^②	<i>d</i> _{T1} ^③	<i>B</i> _G ^④	H Type					
							<i>d</i> _s	<i>e</i>	<i>t</i>			
AH3172	Tr400×5	340	229	238	376.42	41	Rc ¹ / ₈	8.5	15	33	35	HN80
AHY3176	Tr400×5	360	232	242	396.67	42	Rc ¹ / ₈	8.5	15	35.7	36	HN80
AH3176	Tr420×5	360	232	242	396.67	42	Rc ¹ / ₈	8.5	15	35.7	36	HN84
AHY3180	Tr420×5	380	240	250	417.17	44	Rc ¹ / ₈	8.5	15	39.5	38	HN84
AH3180	Tr440×5	380	240	250	417.17	44	Rc ¹ / ₈	8.5	15	39.5	38	HN88
AHY3184	Tr440×5	400	266	276	439.17	46	Rc ¹ / ₈	8.5	15	46.5	40	HN88
AH3184	Tr460×5	400	266	276	439.17	46	Rc ¹ / ₈	8.5	15	46.5	40	HN92
AHY3188	Tr460×5	420	270	281	459.42	48	Rc ¹ / ₈	8.5	15	49.8	42	HN92
AHX3188	Tr480×5	420	270	281	459.42	48	Rc ¹ / ₈	8.5	15	49.8	42	HN96
AHY3192	Tr480×5	440	285	296	480.58	49	Rc ¹ / ₈	8.5	15	50.1	43	HN96
AHX3192	Tr510×6	440	285	296	480.58	49	Rc ¹ / ₈	8.5	15	57.9	43	HN102
AHY3196	Tr500×5	460	295	307	501.33	51	Rc ¹ / ₈	8.5	15	54.6	45	HN100
AHX3196	Tr530×6	460	295	307	501.33	51	Rc ¹ / ₈	8.5	15	63.1	45	HN106

Note : The part number for hydraulic adapters has the suffix at the end. E.g. AH3144H

Withdrawal Sleeves

Withdrawal Sleeves

Series
AH(Y)2

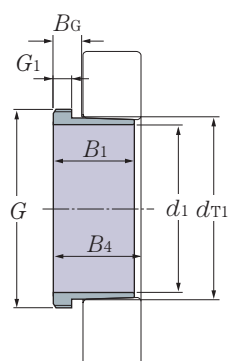

Taper 1:12

Part numbers	Thread ① G	Dimensions mm					Mass kg (approx.)	G ₁	Applicable ^⑤ Nut numbers
		d ₁	B ₁	B ₄ ^②	d _{T1} ^③	B _G ^④			
AH208	M45×1.5	35	25	27	41.50	9	0.081	6	AN09
AH209	M50×1.5	40	26	29	46.67	9	0.095	6	AN10
AH210	M55×2	45	28	31	51.75	10	0.114	7	AN11
AH211	M60×2	50	29	32	56.83	10	0.132	7	AN12
AH212	M65×2	55	32	35	62.00	11	0.161	8	AN13
AH213	M75×2	60	32.5	36	67.08	11	0.213	8	AN15
AH214	M80×2	65	33.5	37	72.17	11	0.240	8	AN16
AH215	M85×2	70	34.5	38	77.25	11	0.259	8	AN17
AH216	M90×2	75	35.5	39	82.33	11	0.284	8	AN18
AH217	M95×2	80	38.5	42	87.50	12	0.314	9	AN19
AH218	M100×2	85	40	44	92.67	12	0.351	9	AN20
AH219	M105×2	90	43	47	97.83	13	0.403	10	AN21
AH220	M110×2	95	45	49	103.00	13	0.481	10	AN22
AH221	M115×2	100	47	51	108.08	14	0.492	11	AN23
AH222	M120×2	105	50	54	113.33	14	0.547	11	AN24
AH224	M130×2	115	53	57	123.50	15	0.679	12	AN26
AH226	M140×2	125	53	57	133.50	15	0.725	12	AN28
AH228	M150×2	135	56	61	143.75	16	0.818	13	AN30
AH230	M160×3	145	60	65	154.00	17	0.963	14	AN32
AH232	M170×3	150	64	69	164.25	18	1.70	15	AN34
AH234	M180×3	160	69	74	174.58	19	1.98	16	AN36
AH236	M190×3	170	69	74	184.58	19	2.14	16	AN38
AHY238	M200×3	180	73	78	194.58	23	2.52	17	AN40
AH238	Tr205×4	180	73	78	194.58	23	2.52	17	HNL41
AHY240	Tr210×4	190	77	82	204.83	24	2.87	18	HN42
AH240	Tr215×4	190	77	82	204.83	24	2.87	18	HNL43
AHY244	Tr230×4	200	85	91	225.58	24	5.49	18	HN46
AH244	Tr235×4	200	85	91	225.58	24	5.49	18	HNL47
AH248	Tr260×4	220	96	102	246.17	28	7.34	22	HNL52
AH252	Tr280×4	240	105	111	266.83	29	8.80	23	HNL56
AH256	Tr300×4	260	105	113	287.00	29	9.42	23	HNL60

① Standard thread shapes and dimensions of the part numbers AH208 to AHY238 are as per JIS B0205-1 and JIS B 0205-4 (general purpose metric screw threads).
Standard thread shapes and dimensions of the part numbers AH238 to AHX256 are as per JIS B 0216 (metric trapezoidal screw threads).

② B₄ dimensions indicate reference dimensions before attachment of withdrawal sleeves.

③ d_{T1} dimensions indicate that it does not meet JIS B 1552 standards.

④ B_G dimensions indicate that it does not meet JIS B 1552 standards.

⑤ Indicates nut to be used at time of disassembly.

Withdrawal Sleeves & Hydraulic Withdrawal Sleeves

Withdrawal Sleeves

Series

AH(Y)22

AH(Y)22·H (Hydraulic)

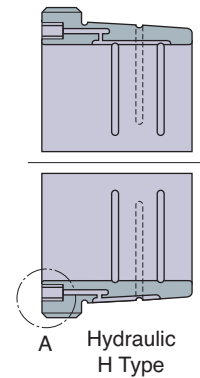
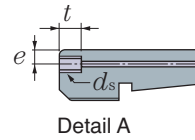
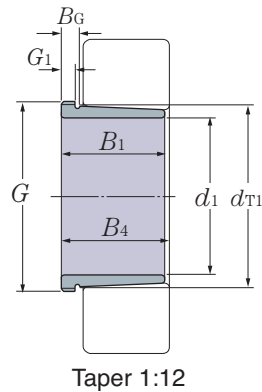

Part numbers	Thread ①	Dimensions mm								Mass kg (approx.)	G ₁	Applicable ^⑤ Nut numbers
		d ₁	B ₁	B ₄ ^②	d _{T1} ^③	B _G ^④	H Type					
	G						d _s	e	t			
AHY2236	M190×3	170	105	110	187.50	20	—	—	—	3.73	17	AN38
AH2236	M200×3	170	105	110	187.50	20	—	—	—	3.73	17	AN40
AHY2238	M200×3	180	112	117	197.75	24	—	—	—	4.25	18	AN40
AH2238	Tr210×4	180	112	117	197.75	24	—	—	—	4.25	18	HN42
AH2240	Tr220×4	190	118	123	208.17	25	—	—	—	4.68	19	HN44
AH2244	Tr240×4	200	130	136	229.17	26	Rc ¹ / ₈	8.5	15	9.10	20	HN48
AH2248	Tr260×4	220	144	150	250.25	27	Rc ¹ / ₈	8.5	15	11.1	21	HN52
AHY2252	Tr280×4	240	155	161	271.00	29	Rc ¹ / ₈	8.5	15	14.0	23	HN56
AH2252	Tr290×4	240	155	161	271.00	29	Rc ¹ / ₈	8.5	15	14.0	23	HN58
AHY2256	Tr300×4	260	155	163	291.08	30	Rc ¹ / ₈	8.5	15	15.2	24	HN60
AH2256	Tr310×5	260	155	163	291.08	30	Rc ¹ / ₈	8.5	15	15.2	24	HN62
AHY2260	Tr320×5	280	170	178	312.17	32	Rc ¹ / ₈	8.5	15	18.1	26	HN64
AH2260	Tr330×5	280	170	178	312.17	32	Rc ¹ / ₈	8.5	15	18.1	26	HN66
AHY2264	Tr340×5	300	180	190	333.08	33	Rc ¹ / ₈	8.5	15	20.2	27	HN68
AH2264	Tr350×5	300	180	190	333.08	33	Rc ¹ / ₈	8.5	15	20.2	27	HN70

① Standard thread shapes and dimensions of the part numbers AHY2236 to AHY2238 are as per JIS B0205-1 and JIS B 0205-4 (general purpose metric screw threads).

Standard thread shapes and dimensions of the part numbers AH2238 to AH2264 are as per JIS B 0216 (metric trapezoidal screw threads).

② B₄ dimensions indicate reference dimensions before attachment of withdrawal sleeves.

③ d_{T1} dimensions indicate that it does not meet JIS B 1552 standards.

④ B_G dimensions indicate that it does not meet JIS B 1552 standards.

⑤ Indicates nut to be used at time of disassembly.

Note : The part number for hydraulic adapters has the suffix at the end. E.g. AH2244H

Withdrawal Sleeves & Hydraulic Withdrawal Sleeves

Withdrawal Sleeves

Series

AH(X,Y)32

AH(X,Y)32··H (Hydraulic)

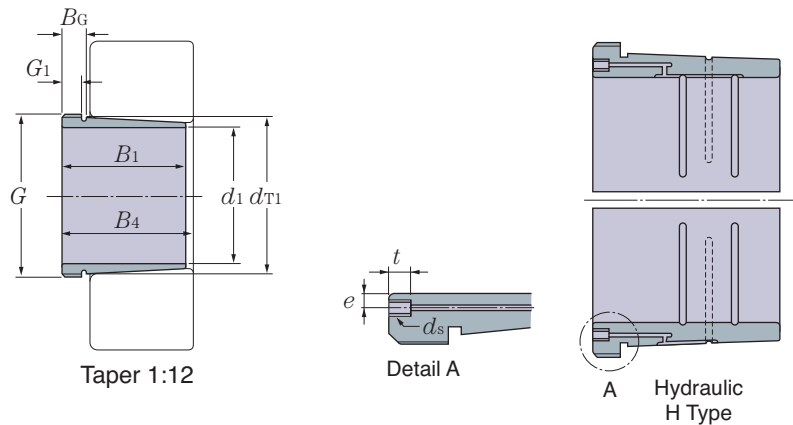

Part numbers	Thread ❶	Dimensions mm						H Type			Mass kg (approx.)	G ₁	Applicable ❺ Nut numbers
		d ₁	B ₁	B ₄ ❷	d _{T1} ❸	B _G ❹	d _s	e	t				
AHX3218	M100×2	85	63	67	94.50	13	—	—	—	0.576	10	AN20	
AH3219	M105×2	90	67	71	99.75	14	—	—	—	0.655	11	AN21	
AHX3220	M110×2	95	73	77	105.25	14	—	—	—	0.767	11	AN22	
AH3221	M115×2	100	78	82	110.67	14	—	—	—	0.911	11	AN23	
AHY3222	M120×2	105	82	86	116.00	14	—	—	—	1.04	11	AN24	
AHX3222	M125×2	105	82	86	116.00	14	—	—	—	1.04	11	AN25	
AHY3224	M130×2	115	90	94	126.50	16	—	—	—	1.30	13	AN26	
AHX3224	M135×2	115	90	94	126.50	16	—	—	—	1.30	13	AN27	
AHY3226	M140×2	125	98	102	137.00	18	—	—	—	1.58	15	AN28	
AHX3226	M145×2	125	98	102	137.00	18	—	—	—	1.58	15	AN29	
AHY3228	M150×2	135	104	109	147.58	18	—	—	—	1.84	15	AN30	
AHX3228	M155×2	135	104	109	147.58	18	—	—	—	1.84	15	AN31	
AHY3230	M160×3	145	114	119	158.25	20	—	—	—	2.22	17	AN32	
AHX3230	M165×3	145	114	119	158.25	20	—	—	—	2.22	17	AN33	
AHY3232	M170×3	150	124	130	168.92	23	—	—	—	4.08	20	AN34	
AH3232	M180×3	150	124	130	168.92	23	—	—	—	4.08	20	AN36	
AHY3234	M180×3	160	134	140	179.42	27	—	—	—	4.8	24	AN36	
AH3234	M190×3	160	134	140	179.42	27	—	—	—	4.8	24	AN38	
AHY3236	M190×3	170	140	146	189.92	27	—	—	—	5.32	24	AN38	
AH3236	M200×3	170	140	146	189.92	27	—	—	—	5.32	24	AN40	
AHY3238	M200×3	180	145	152	200.08	31	—	—	—	5.9	25	AN40	
AH3238	Tr210×4	180	145	152	200.08	31	—	—	—	5.9	25	HN42	
AH3240	Tr220×4	190	153	160	210.75	31	—	—	—	6.68	25	HN44	
AH3244	Tr240×4	200	181	189	233.00	33	—	—	—	13.9	27	HN48	
AH3248	Tr260×4	220	189	197	253.50	35	—	—	—	16.0	29	HN52	
AH3252	Tr280×4	240	205	213	274.75	36	—	—	—	19.1	30	HN56	
AH3256	Tr300×4	260	212	220	295.17	38	—	—	—	21.5	32	HN60	

❶ Standard thread shapes and dimensions of the part numbers AHX3218 to AHY3238 are as per JIS B0205-1 and JIS B 0205-4 (general purpose metric screw threads).

Standard thread shapes and dimensions of the part numbers AH3238 to AHX3296 are as per JIS B 0216 (metric trapezoidal screw threads).

❷ B₄ dimensions indicate reference dimensions before attachment of withdrawal sleeves.

❸ d_{T1} dimensions indicate that it does not meet JIS B 1552 standards.

❹ B_G dimensions indicate that it does not meet JIS B 1552 standards.

❺ Indicates nut to be used at time of disassembly.

Withdrawal Sleeves & Hydraulic Withdrawal Sleeves

Part numbers	Thread ① <i>G</i>	Dimensions mm								Mass kg (approx.)	<i>G</i> ₁	Applicable ^⑤ Nut numbers
		<i>d</i> ₁	<i>B</i> ₁	<i>B</i> ₄ ^②	<i>d</i> _{T1} ^③	<i>B</i> _G ^④	H Type					
							<i>d</i> _s	<i>e</i>	<i>t</i>			
AHY3260	Tr320×5	280	228	236	316.33	40	Rc ¹ / ₈	8.5	15	26.0	34	HN64
AH3260	Tr330×5	280	228	236	316.33	40	Rc ¹ / ₈	8.5	15	26.0	34	HN66
AHY3264	Tr340×5	300	246	254	337.67	42	Rc ¹ / ₈	8.5	15	30.6	36	HN68
AH3264	Tr350×5	300	246	254	337.67	42	Rc ¹ / ₈	8.5	15	30.6	36	HN70
AHY3268	Tr360×5	320	264	273	359.08	44	Rc ¹ / ₈	8.5	15	35.8	38	HN72
AH3268	Tr370×5	320	264	273	359.08	44	Rc ¹ / ₈	8.5	15	35.8	38	HN74
AHY3272	Tr380×5	340	274	283	379.75	46	Rc ¹ / ₈	8.5	15	41.6	40	HN76
AH3272	Tr400×5	340	274	283	379.75	46	Rc ¹ / ₈	8.5	15	41.6	40	HN80
AHY3276	Tr400×5	360	284	294	400.50	48	Rc ¹ / ₈	8.5	15	46.3	42	HN80
AH3276	Tr420×5	360	284	294	400.50	48	Rc ¹ / ₈	8.5	15	46.3	42	HN84
AHY3280	Tr420×5	380	302	312	421.83	50	Rc ¹ / ₈	8.5	15	52.5	44	HN84
AH3280	Tr440×5	380	302	312	421.83	50	Rc ¹ / ₈	8.5	15	52.5	44	HN88
AHY3284	Tr440×5	400	321	331	443.25	52	Rc ¹ / ₈	8.5	15	59.7	46	HN88
AH3284	Tr460×5	400	321	331	443.25	52	Rc ¹ / ₈	8.5	15	59.7	46	HN92
AHY3288	Tr460×5	420	330	341	463.92	54	Rc ¹ / ₈	8.5	15	64.8	48	HN92
AHX3288	Tr480×5	420	330	341	463.92	54	Rc ¹ / ₈	8.5	15	64.8	48	HN96
AHY3292	Tr480×5	440	349	360	485.33	56	Rc ¹ / ₈	8.5	15	75.2	50	HN96
AHX3292	Tr510×5	440	349	360	485.33	56	Rc ¹ / ₈	8.5	15	75.2	50	HN102
AHY3296	Tr500×5	460	364	376	506.50	58	Rc ¹ / ₈	8.5	15	83.1	52	HN100
AHX3296	Tr530×6	460	364	376	506.50	58	Rc ¹ / ₈	8.5	15	83.1	52	HN106

Note : The part number for hydraulic adapters has the suffix at the end. E.g. **AHY3260H**

Withdrawal Sleeves

Withdrawal Sleeves

Series
AH(X,Y)3

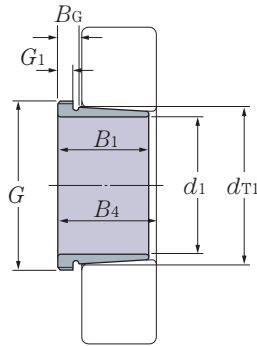

Taper 1:12

Part numbers	Thread ① <i>G</i>	Dimensions mm					Mass kg (approx.)	<i>G</i> ₁	Applicable ^⑤ Nut numbers
		<i>d</i> ₁	<i>B</i> ₁	<i>B</i> ₄ ^②	<i>d</i> _{T1} ^③	<i>B</i> _G ^④			
AH308	M45×1.5	35	29	32	41.92	9	0.090	6	AN09
AH309	M50×1.5	40	31	34	47.08	9	0.109	6	AN10
AHX310	M55×2	45	35	38	52.33	10	0.137	7	AN11
AHX311	M60×2	50	37	40	57.38	11.5	0.161	7	AN12
AHX312	M65×2	55	40	43	62.38	14.5	0.189	8	AN13
AHY313	M70×2	60	42	45	67.83	11	0.253	8	AN14
AH313	M75×2	60	42	45	67.83	11	0.253	8	AN15
AHY314	M75×2	65	43	47	73.00	11	0.28	8	AN15
AH314	M80×2	65	43	47	73.00	11	0.28	8	AN16
AHY315	M80×2	70	45	49	78.17	11	0.313	8	AN16
AH315	M85×2	70	45	49	78.17	11	0.313	8	AN17
AH316	M90×2	75	48	52	83.42	11	0.365	8	AN18
AHX317	M95×2	80	52	56	88.67	12	0.429	9	AN19
AHX318	M100×2	85	53	57	93.75	12	0.461	9	AN20
AHX319	M105×2	90	57	61	99.00	13	0.532	10	AN21
AHX320	M110×2	95	59	63	104.17	13	0.582	10	AN22
AHX321	M115×2	100	62	66	109.25	15	0.665	12	AN23
AHX322	M120×2	105	63	67	114.33	15	0.663	12	AN24
AHX324	M130×2	115	69	73	124.75	16	0.875	13	AN26
AHX326	M140×2	125	74	78	135.08	17	1.03	14	AN28
AHX328	M150×2	135	77	82	145.42	17	1.15	14	AN30
AHY330	M160×3	145	83	88	155.83	18	1.55	15	AN32
AHX330	M165×3	145	83	88	155.83	18	1.55	15	AN33
AHY332	M170×3	150	88	93	166.17	19	2.73	16	AN34
AH332	M180×3	150	88	93	166.17	19	2.73	16	AN36
AHY334	M180×3	160	93	98	176.50	20	3.19	17	AN36
AH334	M190×3	160	93	98	176.50	20	3.19	17	AN38

① Standard thread shapes and dimensions are as per JIS B 0205-1 and JIS B 0205-4 (general purpose metric screw threads).

② *B*₄ dimensions indicate reference dimensions before attachment of withdrawal sleeves.

③ *d*_{T1} dimensions indicate that it does not meet JIS B 1552 standards.

④ *B*_G dimensions indicate that it does not meet JIS B 1552 standards.

⑤ Indicates nut to be used at time of disassembly.

Withdrawal Sleeves & Hydraulic Withdrawal Sleeves

Withdrawal Sleeves

Series

AH(X,Y)23

AH(X,Y)23·H (Hydraulic)

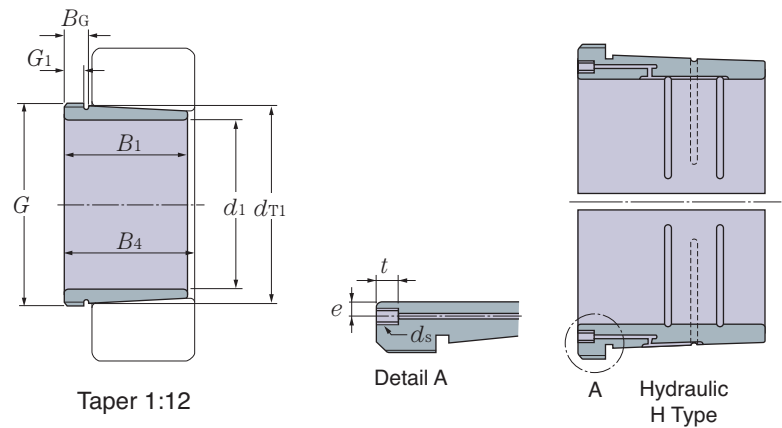

Part numbers	Thread ①	Dimensions mm								Mass kg (approx.)	G ₁	Applicable ^⑤ Nut numbers
		d ₁	B ₁	B ₄ ^②	d _{T1} ^③	B _G ^④	H Type					
	G						d _s	e	t			
AH2308	M45×1.5	35	40	43	42.75	10	—	—	—	0.128	7	AN09
AH2309	M50×1.5	40	44	47	48.00	11	—	—	—	0.164	7	AN10
AHX2310	M55×2	45	50	53	53.17	15	—	—	—	0.209	9	AN11
AHX2311	M60×2	50	54	57	58.42	16	—	—	—	0.253	10	AN12
AHX2312	M65×2	55	58	61	63.63	17.5	—	—	—	0.297	11	AN13
AHY2313	M70×2	60	61	64	69.08	15	—	—	—	0.395	12	AN14
AH2313	M75×2	60	61	64	69.08	15	—	—	—	0.395	12	AN15
AHY2314	M75×2	65	64	68	74.42	15	—	—	—	0.466	12	AN15
AHX2314	M80×2	65	64	68	74.42	15	—	—	—	0.466	12	AN16
AHY2315	M80×2	70	68	72	79.75	15	—	—	—	0.534	12	AN16
AHX2315	M85×2	70	68	72	79.75	15	—	—	—	0.534	12	AN17
AHX2316	M90×2	75	71	75	85.00	15	—	—	—	0.597	12	AN18
AHX2317	M95×2	80	74	78	90.17	16	—	—	—	0.670	13	AN19
AHX2318	M100×2	85	79	83	95.50	17	—	—	—	0.779	14	AN20
AHX2319	M105×2	90	85	89	100.83	19	—	—	—	0.886	16	AN21
AHX2320	M110×2	95	90	94	106.25	19	—	—	—	0.998	16	AN22
AH2321	M120×2	100	94	98	111.58	19	—	—	—	1.29	16	AN24
AHY2322	M120×2	105	98	102	116.92	19	—	—	—	1.35	16	AN24
AHX2322	M125×2	105	98	102	116.92	19	—	—	—	1.35	16	AN25
AHY2324	M130×2	115	105	109	127.42	20	—	—	—	1.60	17	AN26
AHX2324	M135×2	115	105	109	127.42	20	—	—	—	1.60	17	AN27
AHY2326	M140×2	125	115	119	138.08	22	—	—	—	1.97	19	AN28
AHX2326	M145×2	125	115	119	138.08	22	—	—	—	1.97	19	AN29
AHY2328	M150×2	135	125	130	148.92	23	—	—	—	2.33	20	AN30
AHX2328	M155×3	135	125	130	148.92	23	—	—	—	2.33	20	AN31
AHY2330	M160×3	145	135	140	159.42	27	—	—	—	2.82	24	AN32
AHX2330	M165×3	145	135	140	159.42	27	—	—	—	2.82	24	AN33
AHY2332	M170×3	150	140	146	169.92	27	—	—	—	4.72	24	AN34
AH2332	M180×3	150	140	146	169.92	27	—	—	—	4.72	24	AN36
AHY2334	M180×3	160	146	152	180.42	27	—	—	—	5.25	24	AN36

① Standard thread shapes and dimensions are as per JIS B 0205-1 and JIS B 0205-4 (general purpose metric screw threads).

② B₄ dimensions indicate reference dimensions before attachment of withdrawal sleeves.

③ d_{T1} dimensions indicate that it does not meet JIS B 1552 standards.

④ B_G dimensions indicate that it does not meet JIS B 1552 standards.

⑤ Indicates nut to be used at time of disassembly.

Note : Underlined numbers in the table differ from JIS B 1552.

Withdrawal Sleeves & Hydraulic Withdrawal Sleeves

Withdrawal Sleeves

Series

AH(X,Y)23

AH(X,Y)23·H (Hydraulic)

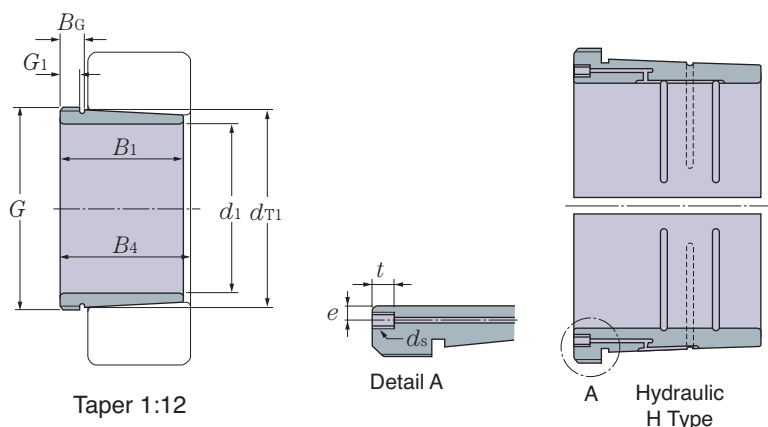

Part numbers	Thread ① G	Dimensions mm					H Type			Mass kg (approx.)	G ₁	Applicable ⑤ Nut numbers
		d ₁	B ₁	B ₄ ②	d _{T1} ③	B _G ④	d _s	e	t			
AH2334	M190×3	160	146	152	180.42	27	—	—	—	5.25	24	AN38
AHY2336	M190×3	170	154	160	190.92	29	—	—	—	5.83	26	AN38
AH2336	M200×3	170	154	160	190.92	29	—	—	—	5.83	26	AN40
AHY2338	M200×3	180	160	167	201.25	32	—	—	—	6.63	26	AN40
AH2338	Tr210×4	180	160	167	201.25	32	—	—	—	6.63	26	HN42
AH2340	Tr220×4	190	170	177	211.75	36	—	—	—	7.54	30	HN44
AH2344	Tr240×4	200	181	189	232.75	36	Rc $\frac{1}{8}$	8.5	15	13.5	30	HN48
AH2348	Tr260×4	220	189	197	253.42	36	Rc $\frac{1}{8}$	8.5	15	15.5	30	HN52
AH2352	Tr290×4	240	205	213	274.75	36	Rc $\frac{1}{8}$	8.5	15	19.6	30	HN58
AH2356	Tr310×5	260	212	220	295.33	36	Rc $\frac{1}{8}$	8.5	15	21.6	30	HN62

① Standard thread shapes and dimensions of the part numbers **AH2334** to **AHY2338** are as per JIS B 0205-1 and JIS B 0205-4 (general purpose metric screw threads).

Standard thread shapes and dimensions of the part numbers **AH2338** to **AH2356** are as per JIS B 0216 (metric trapezoidal screw threads).

② B₄ dimensions indicate reference dimensions before attachment of withdrawal sleeves.

③ d_{T1} dimensions indicate that it does not meet JIS B 1552 standards.

④ B_G dimensions indicate that it does not meet JIS B 1552 standards.

⑤ Indicates nut to be used at time of disassembly.

Note : The part number for hydraulic adapters has the suffix at the end. E.g. **AH2344H**

Withdrawal Sleeves & Hydraulic Withdrawal Sleeves

Withdrawal Sleeves

Series

AH(X)240

AH(X)240·H (Hydraulic)

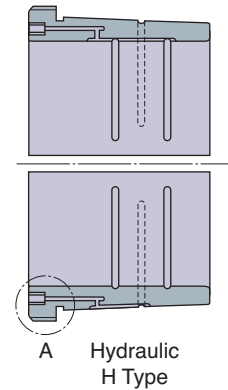
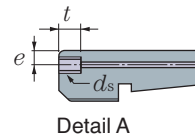
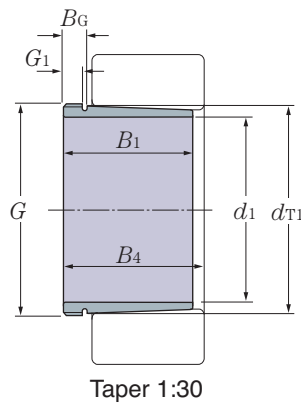

Part numbers	Thread ①	Dimensions mm								Mass kg (approx.)	G ₁	Applicable ^⑤ Nut numbers
		d ₁	B ₁	B ₄ ^②	d _{T1} ^③	B _G ^④	H Type					
	G						d _s	e	t			
AH24024	M125×2	115	73	82	122.20	16	—	—	—	0.650	13	AN25
AH24026	M135×2	125	83	93	132.53	17	—	—	—	0.840	14	AN27
AH24028	M145×2	135	83	93	142.53	17	—	—	—	0.910	14	AN29
AH24030	M155×3	145	90	101	152.47	18	—	—	—	1.04	15	AN31
AH24032	M170×3	150	95	106	162.93	18	—	—	—	2.33	15	AN34
AH24034	M180×3	160	106	117	173.23	20	—	—	—	2.80	16	AN36
AH24036	M190×3	170	116	127	183.57	20	—	—	—	3.10	16	AN38
AH24038	M200×3	180	118	131	193.57	24	—	—	—	3.50	18	AN40
AH24040	Tr210×4	190	127	140	203.87	24	—	—	—	3.93	18	HN42
AH24044	Tr230×4	200	138	152	224.20	26	M8	7.5	12	8.25	20	HN46
AH24048	Tr250×4	220	138	153	244.23	26	M8	7.5	12	8.98	20	HN50
AHX24052	Tr280×4	240	162	178	265.00	28	M8	7.5	12	11.8	22	HN56
AH24052	Tr270×4	240	162	178	265.00	28	M8	7.5	12	11.8	22	HN54
AHX24056	Tr300×4	260	162	179	285.03	28	M8	7.5	12	12.8	22	HN60
AH24056	Tr290×4	260	162	179	285.03	28	M8	7.5	12	12.8	22	HN58
AHX24060	Tr320×5	280	184	202	305.73	30	M8	7.5	12	15.5	24	HN64
AH24060	Tr310×5	280	184	202	305.73	30	M8	7.5	12	15.5	24	HN62
AHX24064	<u>Tr330×5</u>	300	184	202	325.73	30	M8	7.5	12	16.6	24	<u>HN66</u>
AH24064	<u>Tr340×5</u>	300	184	202	325.73	30	M8	7.5	12	16.6	24	<u>HN68</u>
AH24068	Tr360×5	320	206	225	346.43	32	Rc ¹ / ₈	8.5	15	21.7	26	HNL72
AH24072	Tr380×5	340	206	226	366.47	32	Rc ¹ / ₈	8.5	15	22.7	26	HNL76
AH24076	Tr400×5	360	208	228	386.47	34	Rc ¹ / ₈	8.5	15	23.7	28	HNL80
AH24080	Tr420×5	380	228	248	407.13	34	Rc ¹ / ₈	8.5	15	27.1	28	HNL84
AH24084	Tr440×5	400	230	252	427.20	36	Rc ¹ / ₈	8.5	15	29.0	30	HNL88
AH24088	Tr460×5	420	242	264	447.60	36	Rc ¹ / ₈	8.5	15	31.9	30	HNL92

① Standard thread shapes and dimensions of the part numbers AH24024 to AH24038 are as per JIS B 0205-1 and JIS B 0205-4 (general purpose metric screw threads). Standard thread shapes and dimensions of the part numbers AH24040 to AH24088 are as per JIS B 0216 (metric trapezoidal screw threads).

② B₄ dimensions indicate reference dimensions before attachment of withdrawal sleeves.

③ d_{T1} dimensions indicate that it does not meet JIS B 1552 standards.

④ B_G dimensions indicate that it does not meet JIS B 1552 standards.

⑤ Indicates nut to be used at time of disassembly.

Note : 1) The part number for hydraulic adapters has the suffix at the end. E.g. AH24044H

2) Underlined numbers in the table differ to JIS B 1552.

Withdrawal Sleeves & Hydraulic Withdrawal Sleeves

Withdrawal Sleeves

Series

AH241

AH241·H (Hydraulic)

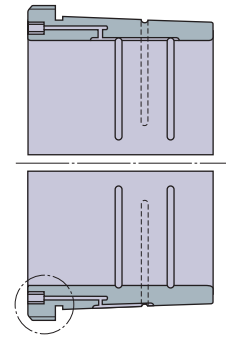
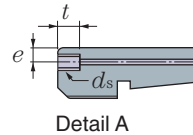
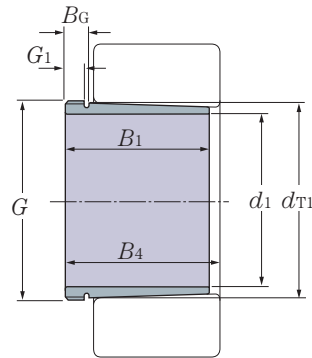

A Hydraulic H Type

Part numbers	Thread ① G	Dimensions mm						H Type			Mass kg (approx.)	G ₁	Applicable ^⑤ Nut numbers
		d ₁	B ₁	B ₄ ^②	d _{T1} ^③	B _G ^④	d _s	e	t				
AH24122	M115×2	105	82	91	112.50	16	—	—	—	0.730	13	AN23	
AH24124	M130×2	115	93	102	122.87	16	—	—	—	1.00	13	AN26	
AH24126	M140×2	125	94	104	132.90	17	—	—	—	1.11	14	AN28	
AH24128	M150×2	135	99	109	143.07	17	—	—	—	1.25	14	AN30	
AH24130	M160×3	145	115	126	153.60	18	—	—	—	1.56	15	AN32	
AH24132	M170×3	150	124	135	163.90	18	—	—	—	3.00	15	AN34	
AH24134	M180×3	160	125	136	173.90	19	—	—	—	3.21	16	AN36	
AH24136	M190×3	170	134	145	184.20	19	—	—	—	3.68	16	AN38	
AH24138	M200×3	180	146	159	194.50	24	—	—	—	4.28	18	AN40	
AH24140	Tr210×4	190	158	171	204.90	24	M6	3.5	9	5.10	18	HN42	
AH24144	Tr230×4	200	170	184	225.27	26	M8	7.5	12	10.2	20	HN46	
AH24148	Tr260×4	220	180	195	245.63	26	Rc ¹ / ₈	8.5	15	12.5	20	HN52	
AH24152	Tr280×4	240	202	218	266.33	28	Rc ¹ / ₈	8.5	15	15.4	22	HN56	
AH24156	Tr300×4	260	202	219	286.37	28	Rc ¹ / ₈	8.5	15	16.3	22	HN60	
AH24160	Tr320×5	280	224	242	307.07	30	Rc ¹ / ₈	8.5	15	19.5	24	HN64	
AH24164	Tr340×5	300	242	260	327.67	30	Rc ¹ / ₈	8.5	15	21.4	24	HN68	
AH24168	Tr360×5	320	269	288	348.53	32	Rc ¹ / ₈	8.5	15	27.1	26	HNL72	
AH24172	Tr380×5	340	269	289	368.57	32	Rc ¹ / ₈	8.5	15	29.6	26	HNL76	
AH24176	Tr400×5	360	271	291	388.57	34	Rc ¹ / ₈	8.5	15	31.3	28	HNL80	
AH24180	Tr420×5	380	278	298	408.80	34	Rc ¹ / ₈	8.5	15	34.4	28	HNL84	
AH24184	Tr440×5	400	310	332	429.87	36	Rc ¹ / ₈	8.5	15	40.3	30	HNL88	
AH24188	Tr460×5	420	310	332	449.87	36	Rc ¹ / ₈	8.5	15	42.3	30	HNL92	
AH24192	Tr480×5	440	332	355	470.57	38	Rc ¹ / ₈	8.5	15	47.4	32	HNL96	

① Standard thread shapes and dimensions of the part numbers AH24122 to AH24138 are as per JIS B 0205-1 and JIS B 0205-4 (general purpose metric screw threads).

Standard thread shapes and dimensions of the part numbers AH24140 to AH24192 are as per JIS B 0216 (metric trapezoidal screw threads).

② B₄ dimensions indicate reference dimensions before attachment of withdrawal sleeves.

③ d_{T1} dimensions indicate that it does not meet JIS B 1552 standards.

④ B_G dimensions indicate that it does not meet JIS B 1552 standards.

⑤ Indicates nut to be used at time of disassembly.

Note : The part number for hydraulic adapters has the suffix at the end. E.g. AH24140H

Withdrawal Sleeves & Hydraulic Withdrawal Sleeves

Withdrawal Sleeves

Series

AH39

AH39·H (Hydraulic)

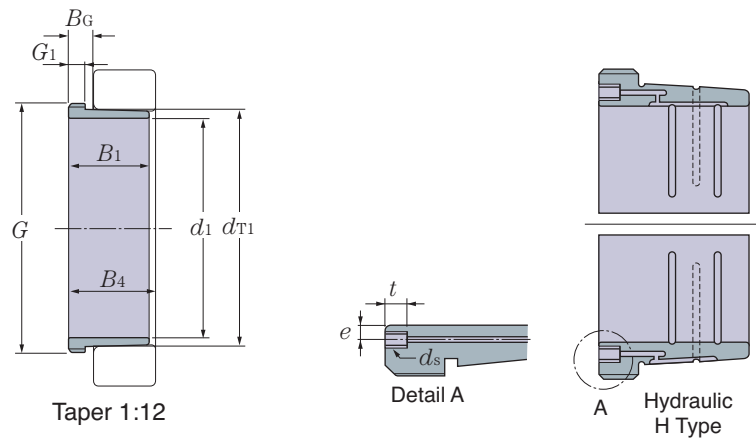

Part numbers	Thread ①	Dimensions mm								Mass kg (approx.)	G ₁	Applicable ^⑤ Nut numbers
		d ₁	B ₁	B ₄ ^②	d _{T1} ^③	B _G ^④	H Type					
	G						d _s	e	t			
AH3934	M180×3	160	59	64	174.00	16	—	—	—	1.59	13	ANL36
AH3936	M190×3	170	66	71	184.58	16	—	—	—	1.91	13	ANL38
AH3938	M200×3	180	66	71	194.33	19	—	—	—	2.02	13	ANL40
AH3940	Tr210×4	190	77	83	205.08	22	—	—	—	2.62	16	HN42
AH3944	Tr230×4	200	77	83	225.08	22	M8	7.5	12	4.83	16	HN46
AH3948	Tr250×4	220	77	83	245.08	22	M8	7.5	12	5.29	16	HN50
AH3952	Tr280×4	240	94	100	266.33	24	M8	7.5	12	7.06	18	HNL56
AH3956	Tr300×4	260	94	100	286.33	24	M8	7.5	12	7.70	18	HNL60
AH3960	Tr320×5	280	112	119	307.67	27	M8	7.5	12	10.1	21	HNL64
AH3964	Tr340×5	300	112	119	327.67	27	M8	7.5	12	10.8	21	HNL68
AH3968	Tr360×5	320	112	119	347.67	27	M8	7.5	12	12.4	21	HNL72
AH3972	Tr380×5	340	112	119	367.67	27	M8	7.5	12	13.1	21	HNL76
AH3976	Tr400×5	360	130	138	389.17	28	M8	7.5	12	15.9	22	HNL80
AH3980	Tr420×5	380	130	138	409.17	28	M8	7.5	12	17.2	20	HNL84
AH3984	Tr440×5	400	130	138	429.17	28	M8	7.5	12	18.1	22	HNL88
AH3988	Tr460×5	420	145	153	450.17	31	Rc ¹ / ₈	8.5	15	21.5	25	HNL92
AH3992	Tr480×5	440	145	153	470.17	31	Rc ¹ / ₈	8.5	15	22.5	25	HNL96
AH3996	Tr500×5	460	158	167	491.08	34	Rc ¹ / ₈	8.5	15	26.0	28	HNL100

① Standard thread shapes and dimensions of the part numbers **AH3934** to **AH3938** are as per JIS B 0205-1 and JIS B 0205-4 (general purpose metric screw threads).

Standard thread shapes and dimensions of the part numbers **AH3940** to **AH3996** are as per JIS B 0216 (metric trapezoidal screw threads).

② B₄ dimensions indicate reference dimensions before attachment of withdrawal sleeves.

③ d_{T1} dimensions indicate that it does not meet JIS B 1552 standards.

④ B_G dimensions indicate that it does not meet JIS B 1552 standards.

⑤ Indicates nut to be used at time of disassembly.

Note : The part number for hydraulic adapters has the suffix at the end. E.g. **AH3944H**

Locknuts & Hydraulic Sleeve Nuts

Locknuts

Series

AN

(For adapter sleeve,
withdrawal sleeve and shaft)

Nut with Lockwasher

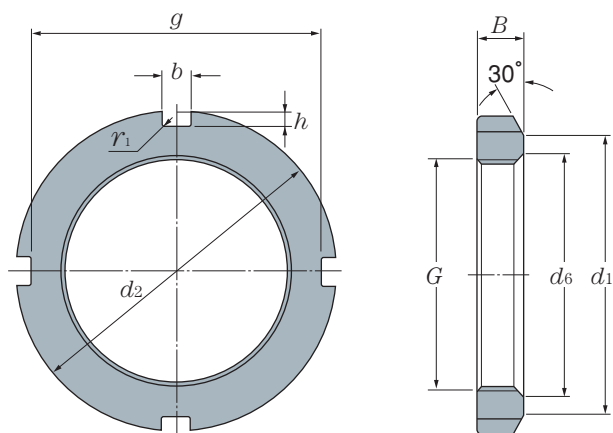

Part numbers	Thread ① <i>G</i>	Dimensions mm							
		<i>d</i> ₁	<i>d</i> ₂	<i>B</i>	<i>b</i>	<i>h</i>	<i>d</i> ₆	<i>g</i>	<i>r</i> ₁ max
AN00	M10×0.75	13.5	18	4	3	2	10.5	14	0.4
AN01	M12×1	17	22	4	3	2	12.5	18	0.4
AN02	M15×1	21	25	5	4	2	15.5	21	0.4
AN03	M17×1	24	28	5	4	2	17.5	24	0.4
AN04	M20×1	26	32	6	4	2	20.5	28	0.4
AN/22	M22×1	28	34	6	4	2	22.5	30	0.4
AN05	M25×1.5	32	38	7	5	2	25.8	34	0.4
AN/28	M28×1.5	36	42	7	5	2	28.8	38	0.4
AN06	M30×1.5	38	45	7	5	2	30.8	41	0.4
AN/32	M32×1.5	40	48	8	5	2	32.8	44	0.4
AN07	M35×1.5	44	52	8	5	2	35.8	48	0.4
AN08	M40×1.5	50	58	9	6	2.5	40.8	53	0.5
AN09	M45×1.5	56	65	10	6	2.5	45.8	60	0.5
AN10	M50×1.5	61	70	11	6	2.5	50.8	65	0.5
AN11	M55×2	67	75	11	7	3	56	69	0.5
AN12	M60×2	73	80	11	7	3	61	74	0.5
AN13	M65×2	79	85	12	7	3	66	79	0.5
AN14	M70×2	85	92	12	8	3.5	71	85	0.5
AN15	M75×2	90	98	13	8	3.5	76	91	0.5
AN16	M80×2	95	105	15	8	3.5	81	98	0.6
AN17	M85×2	102	110	16	8	3.5	86	103	0.6
AN18	M90×2	108	120	16	10	4	91	112	0.6
AN19	M95×2	113	125	17	10	4	96	117	0.6
AN20	M100×2	120	130	18	10	4	101	122	0.6
AN21	M105×2	126	140	18	12	5	106	130	0.7
AN22	M110×2	133	145	19	12	5	111	135	0.7
AN23	M115×2	137	150	19	12	5	116	140	0.7
AN24	M120×2	138	155	20	12	5	121	145	0.7
AN25	M125×2	148	160	21	12	5	126	150	0.7
AN26	M130×2	149	165	21	12	5	131	155	0.7
AN27	M135×2	160	175	22	14	6	136	163	0.7
AN28	M140×2	160	180	22	14	6	141	168	0.7
AN29	M145×2	171	190	24	14	6	146	178	0.7

① Standard thread shapes and dimensions are as per JIS B 0205-1 and JIS B 0205-4 (general purpose metric screw threads).

Note : Locknut series AN is used for adapter series H (HE, HS)2, H (HE, HS)3, H (HE, HS)23, and H (HE)31.

Locknuts & Hydraulic Sleeve Nuts

Mass kg (approx.)	Applicable parts	
	Lockwasher	Lockplate
0.005	AW00(X)	—
0.007	AW01(X)	—
0.010	AW02(X)	—
0.013	AW03(X)	—
0.019	AW04(X)	—
0.023	AW/22(X)	—
0.025	AW05(X)	—
0.040	AW/28(X)	—
0.043	AW06(X)	—
0.058	AW/32(X)	—
0.053	AW07(X)	—
0.085	AW08(X)	—
0.119	AW09(X)	—
0.148	AW10(X)	—
0.158	AW11(X)	—
0.174	AW12(X)	—
0.203	AW13(X)	—
0.242	AW14(X)	—
0.287	AW15(X)	—
0.397	AW16(X)	—
0.451	AW17(X)	—
0.556	AW18(X)	—
0.658	AW19(X)	—
0.698	AW20(X)	—
0.845	AW21(X)	—
0.965	AW22(X)	—
1.01	AW23(X)	—
1.08	AW24(X)	—
1.19	AW25(X)	—
1.25	AW26(X)	—
1.55	AW27(X)	—
1.56	AW28(X)	—
2.00	AW29(X)	—

Locknuts & Hydraulic Sleeve Nuts

Nut with Lockwasher

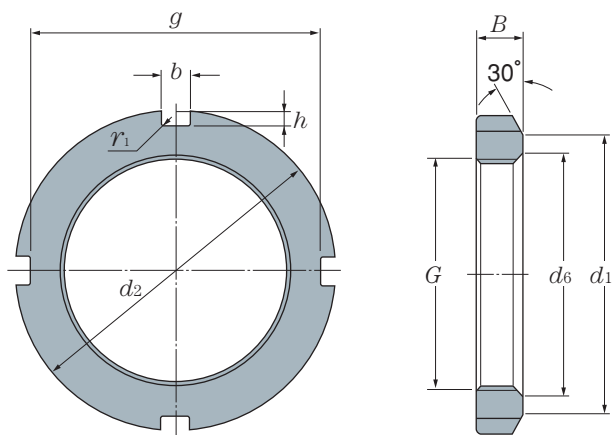

Locknuts

Series

AN

(For adapter sleeve,
withdrawal sleeve and shaft)

AN··SP

AN··SPB

(Hydraulic withdrawal sleeve nuts)

Part numbers	Thread ❶	Dimensions mm							
		d_1	d_2	B	b	h	d_6	g	$r_1 \text{ max}$
AN30	M150×2	171	195	24	14	6	151	183	0.7
AN31	M155×3	182	200	25	16	7	156.5	186	0.7
AN32	M160×3	182	210	25	16	7	161.5	196	0.7
AN33	M165×3	193	210	26	16	7	166.5	196	0.7
AN34	M170×3	193	220	26	16	7	171.5	206	0.7
AN36	M180×3	203	230	27	18	8	181.5	214	0.7
AN38	M190×3	214	240	28	18	8	191.5	224	0.7
AN40	M200×3	226	250	29	18	8	201.5	234	0.7

❶ Standard thread shapes and dimensions are as per JIS B 0205-1 and JIS B 0205-4 (general purpose metric screw threads).

Note : 1) Locknut series **AN** is used for adapter series **H (HE, HS)2**, **H (HE, HS)3**, **H (HE, HS)23**, and **H (HE)31**.

2) The part number for hydraulic sleeve nuts has the suffix at the end. E.g. **AN40SP**

Locknuts & Hydraulic Sleeve Nuts

Hydraulic sleeve nuts

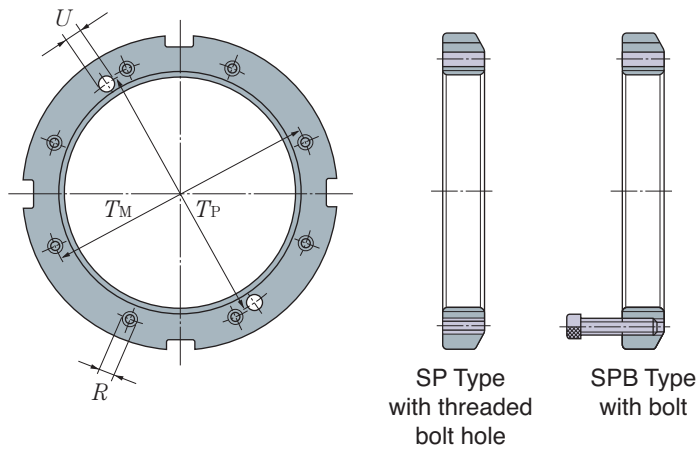

Dimensions mm				Mass kg (approx.)	Applicable parts	
SP, SPB Type					Lockwasher	Lockplate
R (Thread)	T _M	U	T _P			
—	—	—	—	2.03	AW30(X)	—
—	—	—	—	2.21	AW31(X)	—
—	—	—	—	2.59	AW32(X)	—
—	—	—	—	2.43	AW33(X)	—
—	—	—	—	2.80	AW34(X)	—
—	—	—	—	3.07	AW36(X)	—
—	—	—	—	3.39	AW38(X)	—
M10	218	12	217	3.69	AW40(X)	—

3) Protective plates applicable to hydraulic sleeve nuts are listed on P52.

Locknuts & Hydraulic Sleeve Nuts

Locknuts

Series

AN

(For adapte sleever,
withdrawal sleeve and shaft)

AN··SP

AN··SPB

(Hydraulic withdrawal sleeve nuts)

Nut with lockplate

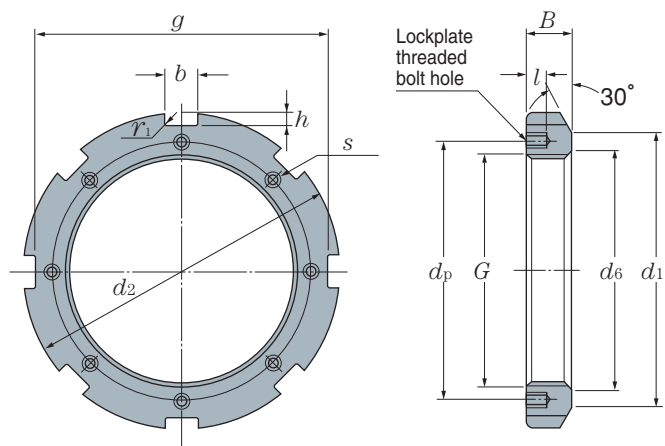

Part numbers	Thread ① G	Dimensions mm								Lockplate threaded bolt hole		
		d ₁	d ₂	B	b	h	d ₆	g	r ₁ max	l	s ②	d _p
AN44	Tr220×4	250	280	32	20	10	222	260	0.8	15	M8	238
AN48	Tr240×4	270	300	34	20	10	242	280	0.8	15	M8	258
AN52	Tr260×4	300	330	36	24	12	262	306	0.8	18	M10	281
AN56	Tr280×4	320	350	38	24	12	282	326	0.8	18	M10	301
AN60	Tr300×4	340	380	40	24	12	302	356	0.8	18	M10	326
AN64	Tr320×5	360	400	42	24	12	322.5	376	0.8	18	M10	345
AN68	Tr340×5	400	440	55	28	15	342.5	410	1	21	M12	372
AN72	Tr360×5	420	460	58	28	15	362.5	430	1	21	M12	392
AN76	Tr380×5	450	490	60	32	18	382.5	454	1	21	M12	414
AN80	Tr400×5	470	520	62	32	18	402.5	484	1	27	M16	439
AN84	Tr420×5	490	540	70	32	18	422.5	504	1	27	M16	459
AN88	Tr440×5	510	560	70	36	20	442.5	520	1	27	M16	477
AN92	Tr460×5	540	580	75	36	20	462.5	540	1	27	M16	497
AN96	Tr480×5	560	620	75	36	20	482.5	580	1	27	M16	527
AN100	Tr500×5	580	630	80	40	23	502.5	584	1	27	M16	539
AN106	Tr530×6	610	670	80	40	23	533	624	1	38	M20	573
AN112	Tr560×6	650	710	85	45	25	563	660	1	38	M20	606

① Standard thread shapes and dimensions are as per JIS B 0216 (metric trapezoidal screw threads).

② Standard thread shapes and dimensions of threaded set screw holes are as per JIS B 0205-1 and JIS B 0205-4 (general purpose metric screw threads).

Note : 1) Locknut series AN is used for adapter series H (HE, HS)23, H (HE)31 and H32.

Locknuts & Hydraulic Sleeve Nuts

Hydraulic sleeve nuts

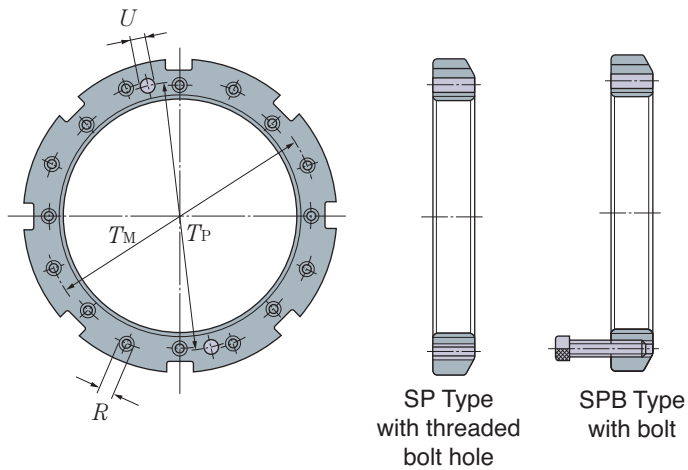

Dimensions mm				Mass kg (approx.)	Applicable parts	
SP, SPB Type					Lockwasher	Lockplate
R (Thread)	T _M	U	T _P			
M16	246	12	237	5.20	AW44(X)	AL44
M16	266	12	257	5.95	AW48(X)	AL44
M16	286	12	277	8.05	AW52(X)	AL52
M16	306	12	297	9.05	AW56(X)	AL52
M16	330	12	317	11.8	—	AL60
M16	350	12	337	13.1	—	AL64
M20	374	12	357	23.1	—	AL68
M20	394	12	377	25.1	—	AL68
M20	416	12	397	30.9	—	AL76
M20	436	12	417	36.9	—	AL80
M24	465	12	437	43.5	—	AL80
M24	485	12	457	45.3	—	AL88
M24	506	12	477	50.4	—	AL88
M24	526	12	497	62.2	—	AL96
M24	546	15	524	63.3	—	AL100
M24	576	15	554	74.6	—	AL106
M24	609	—	—	89.2	—	AL112

2) The part number for hydraulic sleeve nuts has the suffix at the end. E.g. AN44SP

3) Protective plates applicable to hydraulic sleeve nuts are listed on P52.

Locknuts & Hydraulic Sleeve Nuts

Locknuts

Series

ANL

(For adapter sleeve, withdrawal sleeve and shaft)

ANL·SP

ANL·SPB

(Hydraulic withdrawal sleeve nuts)

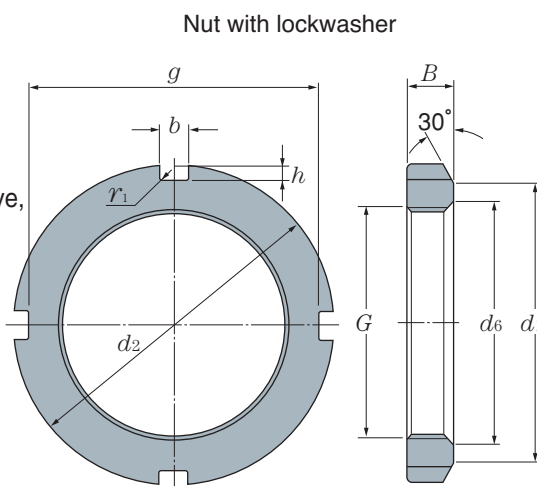

ANL24~ANL40

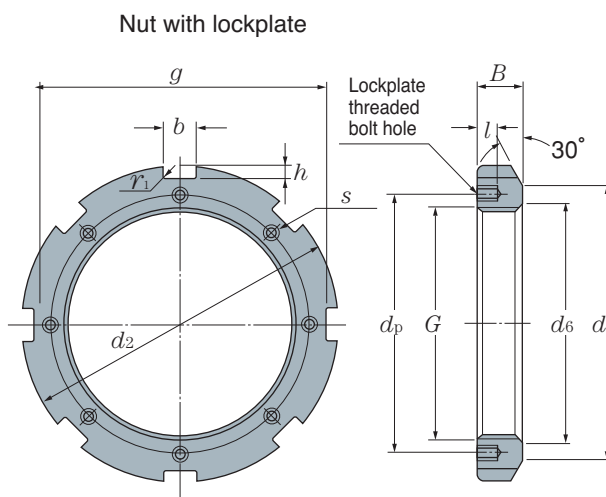

ANL44~ANL126

Part numbers	Thread ① G	Dimensions mm								Lockplate threaded bolt hole		
		d ₁	d ₂	B	b	h	d ₆	g	r ₁ max	l	s ②	d _p
ANL24	M120×2	133	145	20	12	5	121	135	0.7	—	—	—
ANL26	M130×2	143	155	21	12	5	131	145	0.7	—	—	—
ANL28	M140×2	151	165	22	14	6	141	153	0.7	—	—	—
ANL30	M150×2	164	180	24	14	6	151	168	0.7	—	—	—
ANL32	M160×3	174	190	25	16	7	161.5	176	0.7	—	—	—
ANL34	M170×3	184	200	26	16	7	171.5	186	0.7	—	—	—
ANL36	M180×3	192	210	27	18	8	181.5	194	0.7	—	—	—
ANL38	M190×3	202	220	28	18	8	191.5	204	0.7	—	—	—
ANL40	M200×3	218	240	29	18	8	201.5	224	0.7	—	—	—
ANL44	Tr220×4	242	260	30	20	9	222	242	0.8	12	M6	229
ANL48	Tr240×4	270	290	34	20	10	242	270	0.8	15	M8	253
ANL52	Tr260×4	290	310	34	20	10	262	290	0.8	15	M8	273
ANL56	Tr280×4	310	330	38	24	10	282	310	0.8	15	M8	293
ANL60	Tr300×4	336	360	42	24	12	302	336	0.8	15	M8	316
ANL64	Tr320×5	356	380	42	24	12	322.5	356	0.8	15	M8	335
ANL68	Tr340×5	376	400	45	24	12	342.5	376	1	15	M8	355
ANL72	Tr360×5	394	420	45	28	13	362.5	394	1	15	M8	374
ANL76	Tr380×5	422	450	48	28	14	382.5	422	1	18	M10	398
ANL80	Tr400×5	442	470	52	28	14	402.5	442	1	18	M10	418
ANL84	Tr420×5	462	490	52	32	14	422.5	462	1	18	M10	438
ANL88	Tr440×5	490	520	60	32	15	442.5	490	1	21	M12	462
ANL92	Tr460×5	510	540	60	32	15	462.5	510	1	21	M12	482
ANL96	Tr480×5	530	560	60	36	15	482.5	530	1	21	M12	502
ANL100	Tr500×5	550	580	68	36	15	502.5	550	1	21	M12	522
ANL106	Tr530×6	590	630	68	40	20	533	590	1	28	M16	556
ANL112	Tr560×6	610	650	75	40	20	563	610	1	28	M16	581
ANL120	Tr600×6	660	700	75	40	20	603	660	1	28	M16	626
ANL126	Tr630×6	690	730	75	45	20	633	690	1	28	M16	656

① Standard thread shapes and dimensions of the part numbers **ANL24** to **ANL40** are as per JIS B 0205-1 and JIS B 0205-4 (general purpose metric screw threads).

Standard thread shapes and dimensions of the part numbers **ANL44** to **ANL126** are as per JIS B 0216 (metric trapezoidal screw threads).

② Standard thread shapes and dimensions of threaded set screw holes are as per JIS B 0205-1 and JIS B 0205-4 (general purpose metric screw threads).

Locknuts & Hydraulic Sleeve Nuts

Hydraulic sleeve nuts

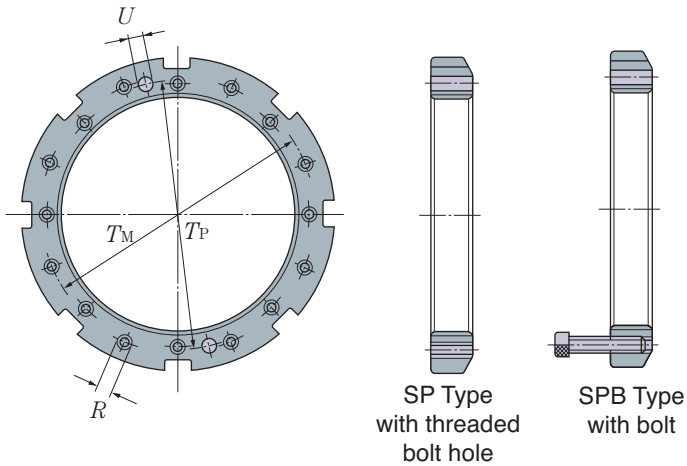

Dimensions mm				Mass kg (approx.)	Applicable parts	
SP, SPB Type					Lockwashers	Lockplate
R (Thread)	T _M	U	T _P			
—	—	—	—	0.780	AWL24(X)	—
—	—	—	—	0.880	AWL26(X)	—
—	—	—	—	0.990	AWL28(X)	—
—	—	—	—	1.38	AWL30(X)	—
—	—	—	—	1.56	AWL32(X)	—
—	—	—	—	1.72	AWL34(X)	—
—	—	—	—	1.95	AWL36(X)	—
—	—	—	—	2.08	AWL38(X)	—
—	—	—	—	2.98	AWL40(X)	—
M10	236	12	237	3.09	—	ALL44
M12	260	12	257	5.16	—	ALL48
M12	280	12	277	5.67	—	ALL48
M12	300	12	297	6.78	—	ALL56
M12	322	12	317	9.62	—	ALL60
M12	342	12	337	9.94	—	ALL64
M12	362	12	357	11.7	—	ALL64
M12	382	12	377	12.0	—	ALL72
M16	406	12	397	14.9	—	ALL76
M16	426	12	417	16.9	—	ALL76
M16	446	12	437	17.4	—	ALL84
M16	468	12	457	26.2	—	ALL88
M16	488	12	477	29.6	—	ALL88
M16	508	12	497	28.3	—	ALL96
M16	530	15	524	33.6	—	ALL96
M16	559	15	554	42.9	—	ALL106
M16	595	—	—	44.4	—	ALL112
M16	635	15	624	54.0	—	ALL106
M16	663	15	654	56.0	—	ALL126

Note : 1) Locknut series **ANL** is used for adapter series **H (HE)30**.

2) The part number for hydraulic sleeve nuts has the suffix at the end. E.g. **ANL44SP**

3) Protective plates applicable to hydraulic sleeve nuts are listed on P52.

Withdrawal sleeve nuts

Nuts

Series

HN

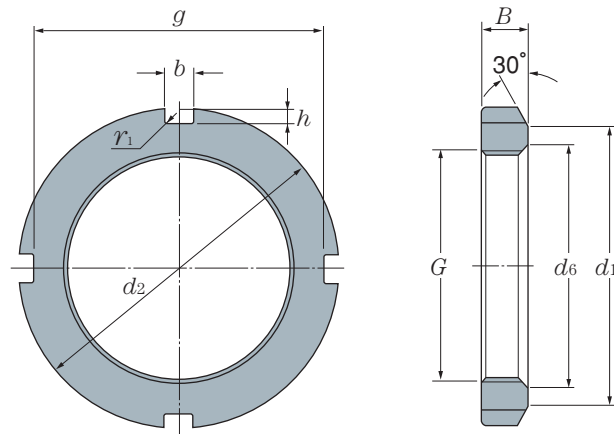

Part numbers	Thread ① <i>G</i>	Dimensions mm					Mass kg (approx.)	Dimensions mm (approx.)		
		<i>d</i> ₁	<i>d</i> ₂	<i>B</i>	<i>b</i>	<i>h</i>		<i>d</i> ₆	<i>g</i>	<i>r</i> ₁ max
HN42	Tr210×4	238	270	30	20	10	4.75	212	250	0.8
HN44	Tr220×4	250	280	32	20	10	5.35	222	260	0.8
HN46	Tr230×4	260	290	34	20	10	5.80	232	270	0.8
HN48	Tr240×4	270	300	34	20	10	6.20	242	280	0.8
HN50	Tr250×4	290	320	36	20	10	7.00	252	300	0.8
HN52	Tr260×4	300	330	36	24	12	8.55	262	306	0.8
HN54	Tr270×4	310	340	38	24	12	9.20	272	316	0.8
HN56	Tr280×4	320	350	38	24	12	10.0	282	326	0.8
HN58	Tr290×4	330	370	40	24	12	11.8	292	346	0.8
HN60	Tr300×4	340	380	40	24	12	12.0	302	356	0.8
HN62	Tr310×5	350	390	42	24	12	13.4	312.5	366	0.8
HN64	Tr320×5	360	400	42	24	12	13.5	322.5	376	0.8
HN66	Tr330×5	380	420	52	28	15	20.4	332.5	390	1
HN68	Tr340×5	400	440	55	28	15	24.5	342.5	410	1
HN70	Tr350×5	410	450	55	28	15	25.2	352.5	420	1
HN72	Tr360×5	420	460	58	28	15	27.5	362.5	430	1
HN74	Tr370×5	430	470	58	28	15	28.2	372.5	440	1
HN76	Tr380×5	450	490	60	32	18	33.5	382.5	454	1
HN80	Tr400×5	470	520	62	32	18	40.0	402.5	484	1
HN84	Tr420×5	490	540	70	32	18	46.9	422.5	504	1
HN88	Tr440×5	510	560	70	36	20	48.5	442.5	520	1
HN92	Tr460×5	540	580	75	36	20	55.0	462.5	540	1
HN96	Tr480×5	560	620	75	36	20	67.0	482.5	580	1
HN100	Tr500×5	580	630	80	40	23	69.0	502.5	584	1
HN102	Tr510×6	590	650	80	40	23	75.0	513	604	1
HN106	Tr530×6	610	670	80	40	23	78.0	533	624	1
HN110	Tr550×6	640	700	80	40	23	92.5	553	654	1
HN112	Tr560×6	650	710	85	45	25	85.6	563	660	1

① Standard thread shapes and dimensions are as per JIS B 0216 (metric trapezoidal screw threads).

Note : Part number **HN54** indicates that it does not meet JIS B 1554 standards.

Withdrawal sleeve nuts

Nuts

Series

HNL

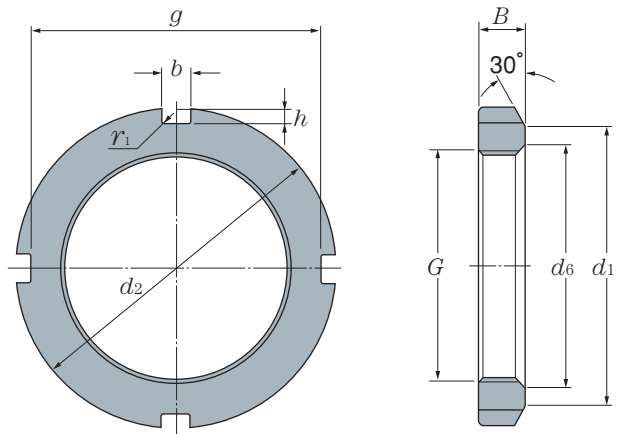

Part numbers	Thread ❶ <i>G</i>	Dimensions mm					Mass kg (approx.)	Dimensions mm (approx.)		
		<i>d</i> ₁	<i>d</i> ₂	<i>B</i>	<i>b</i>	<i>h</i>		<i>d</i> ₆	<i>g</i>	<i>r</i> ₁ max
HNL41	Tr205 × 4	232	250	30	18	8	3.43	207	234	0.8
HNL43	Tr215 × 4	242	260	30	20	9	3.72	217	242	0.8
HNL44	Tr220 × 4	242	260	30	20	9	3.09	222	242	0.8
HNL47	Tr235 × 4	262	280	34	20	9	4.60	237	262	0.8
HNL48	Tr240 × 4	270	290	34	20	10	5.16	242	270	0.8
HNL52	Tr260 × 4	290	310	34	20	10	5.80	262	290	0.8
HNL56	Tr280 × 4	310	330	38	24	10	6.72	282	310	0.8
HNL60	Tr300 × 4	336	360	42	24	12	9.60	302	336	0.8
HNL64	Tr320 × 5	356	380	42	24	12	10.3	322.5	356	1
HNL68	Tr340 × 5	376	400	45	24	12	11.7	342.5	376	1
HNL69	Tr345 × 5	384	410	45	28	13	11.5	347.5	384	1
HNL72	Tr360 × 5	394	420	45	28	13	12.1	362.5	394	1
HNL73	Tr365 × 5	404	430	48	28	13	14.2	367.5	404	1
HNL76	Tr380 × 5	422	450	48	28	14	16.0	382.5	422	1
HNL77	Tr385 × 5	422	450	48	28	14	15.0	387.5	422	1
HNL80	Tr400 × 5	442	470	52	28	14	18.5	402.5	442	1
HNL82	Tr410 × 5	452	480	52	32	14	19.0	412.5	452	1
HNL84	Tr420 × 5	462	490	52	32	14	19.4	422.5	462	1
HNL86	Tr430 × 5	472	500	52	32	14	19.8	432.5	472	1
HNL88	Tr440 × 5	490	520	60	32	15	27.0	442.5	490	1
HNL90	Tr450 × 5	490	520	60	32	15	23.8	452.5	490	1
HNL92	Tr460 × 5	510	540	60	32	15	28.0	462.5	510	1
HNL94	Tr470 × 5	510	540	60	32	15	25.0	472.5	510	1
HNL96	Tr480 × 5	530	560	60	36	15	29.5	482.5	530	1
HNL98	Tr490 × 5	550	580	60	36	15	34.0	492.5	550	1
HNL100	Tr500 × 5	550	580	68	36	15	35.0	502.5	550	1
HNL104	Tr520 × 6	570	600	68	36	15	37.0	523	570	1
HNL106	Tr530 × 6	590	630	68	40	20	47.0	533	590	1
HNL108	Tr540 × 6	590	630	68	40	20	43.5	543	590	1
HNL112	Tr560 × 6	610	650	75	40	20	48.3	563	610	1
HNL118	Tr590 × 6	650	690	75	40	20	57.0	593	650	1
HNL120	Tr600 × 6	660	700	75	40	20	53.8	603	660	1
HNL126	Tr630 × 6	690	730	75	45	20	60.6	633	690	1

❶ Standard thread shapes and dimensions are as per JIS B 0216 (metric trapezoidal screw threads).

Lockwashers

Lockwashers

Series

AW

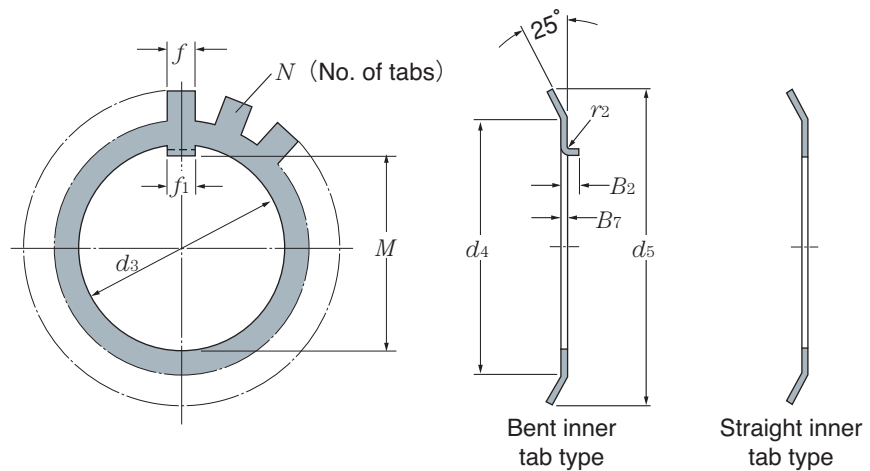

Part numbers		Dimensions mm								Mass kg (approx.) 100 pieces	Dimensions mm		Applicable Locknut numbers
Bent inner tab type	Straight inner tab type	d_3	d_4	d_5	f_1	M	f	B_7	N		Bent inner tab type B_2	r_2	
AW00	AW00X	10	13.5	21	3	8.5	3	1	9	0.131	3	0.5	AN00
AW01	AW01X	12	17	25	3	10.5	3	1	11	0.192	3	0.5	AN01
AW02	AW02X	15	21	28	4	13.5	4	1	13	0.253	3.5	1	AN02
AW03	AW03X	17	24	32	4	15.5	4	1	13	0.313	3.5	1	AN03
AW04	AW04X	20	26	36	4	18.5	4	1	13	0.350	3.5	1	AN04
AW/22	AW/22X	22	28	38	4	20.5	4	1	13	0.394	3.5	1	AN/22
AW05	AW05X	25	32	42	5	23	5	1.25	13	0.640	3.75	1	AN05
AW/28	AW/28X	28	36	46	5	26	5	1.25	13	0.723	3.75	1	AN/28
AW06	AW06X	30	38	49	5	27.5	5	1.25	13	0.780	3.75	1	AN06
AW/32	AW/32X	32	40	52	5	29.5	5	1.25	13	0.839	3.75	1	AN/32
AW07	AW07X	35	44	57	6	32.5	5	1.25	15	1.04	3.75	1	AN07
AW08	AW08X	40	50	62	6	37.5	6	1.25	15	1.23	3.75	1	AN08
AW09	AW09X	45	56	69	6	42.5	6	1.25	17	1.52	3.75	1	AN09
AW10	AW10X	50	61	74	6	47.5	6	1.25	17	1.60	3.75	1	AN10
AW11	AW11X	55	67	81	8	52.5	7	1.5	17	1.96	5.5	1	AN11
AW12	AW12X	60	73	86	8	57.5	7	1.5	17	2.53	5.5	1.2	AN12
AW13	AW13X	65	79	92	8	62.5	7	1.5	19	2.90	5.5	1.2	AN13
AW14	AW14X	70	85	98	8	66.5	8	1.5	19	3.34	5.5	1.2	AN14
AW15	AW15X	75	90	104	8	71.5	8	1.5	19	3.56	5.5	1.2	AN15
AW16	AW16X	80	95	112	10	76.5	8	1.8	19	4.64	5.8	1.2	AN16
AW17	AW17X	85	102	119	10	81.5	8	1.8	19	5.24	5.8	1.2	AN17
AW18	AW18X	90	108	126	10	86.5	10	1.8	19	6.23	5.8	1.2	AN18
AW19	AW19X	95	113	133	10	91.5	10	1.8	19	6.70	5.8	1.2	AN19
AW20	AW20X	100	120	142	12	96.5	10	1.8	19	7.65	7.8	1.2	AN20
AW21	AW21X	105	126	145	12	100.5	12	1.8	19	8.26	7.8	1.2	AN21
AW22	AW22X	110	133	154	12	105.5	12	1.8	19	9.40	7.8	1.2	AN 22
AW23	AW23X	115	137	159	12	110.5	12	2	19	10.8	8	1.5	AN23
AW24	AW24X	120	138	164	14	115	12	2	19	10.5	8	1.5	AN24
AW25	AW25X	125	148	170	14	120	12	2	19	11.8	8	1.5	AN25
AW26	AW26X	130	149	175	14	125	12	2	19	11.3	8	1.5	AN26
AW27	AW27X	135	160	185	14	130	14	2	19	14.4	8	1.5	AN27
AW28	AW28X	140	160	192	16	135	14	2	19	14.2	10	1.5	AN28
AW29	AW29X	145	171	202	16	140	14	2	19	16.8	10	1.5	AN29

Note : 1) Narrow slit type adapter sleeves appended with the code suffix "X" after the H (HE, HS)2, H (HE, HS)3 and H (HE, HS)23 part numbers use straight inner tab washers. Wide slit type adapter sleeves without the suffix code "X" after the adapter part number can use either bent inner tab washers or straight inner tab washers.

2) Bent inner tab type of the part number AW00 and AW01 indicate that they do not meet JIS B 1554 standards.

Lockwashers

Part numbers		Dimensions mm								Mass kg (approx.) 100 pieces	Dimensions mm		Applicable Locknut numbers
Bent inner tab type	Straight inner tab type	d_3	d_4	d_5	f_1	M	f	B_7	N		Bent inner tab type B_2	r_2	
AW30	AW30X	150	171	205	16	145	14	2	19	15.5	10	1.5	AN30
AW31	AW31X	155	182	212	16	147.5	16	2.5	19	20.9	10.5	1.5	AN31
AW32	AW32X	160	182	217	18	154	16	2.5	19	22.2	10.5	1.5	AN32
AW33	AW33X	165	193	222	18	157.5	16	2.5	19	24.1	10.5	1.5	AN33
AW34	AW34X	170	193	232	18	164	16	2.5	19	24.7	10.5	1.5	AN34
AW36	AW36X	180	203	242	20	174	18	2.5	19	26.8	10.5	1.5	AN36
AW38	AW38X	190	214	252	20	184	18	2.5	19	27.8	10.5	1.5	AN38
AW40	AW40X	200	226	262	20	194	18	2.5	19	29.3	10.5	1.5	AN40
AW42	AW42X	210	238	282	24	204	20	3	19	43.2	13	1.5	AN42
AW44	AW44X	220	250	292	24	213	20	3	19	48.0	13	1.5	AN44
AW46	AW46X	230	260	310	24	223	20	3	19	50.0	13	1.5	AN46
AW48	AW48X	240	270	312	24	233	20	3	19	50.2	13	1.5	AN48
AW50	AW50X	250	290	332	24	243	20	3	19	59.1	13	1.5	AN50
AW52	AW52X	260	300	342	28	253	24	3	23	72.9	18	1.5	AN52
AW56	AW56X	280	320	362	28	273	24	3	23	75.9	18	1.5	AN56
AW60	AW60X	300	340	392	32	293	24	3	23	86.4	18	1.5	AN60
AW64	AW64X	320	360	420	32	311	24	4	23	127	19	2	AN64
AW68	AW68X	340	400	460	32	331	28	4	23	180	19	2	AN68
AW72	AW72X	360	420	480	32	351	28	4	23	185	19	2	AN72
AW76	AW76X	380	450	510	36	371	32	4	23	223	19	2	AN76
AW80	AW80X	400	470	540	36	391	32	4	23	244	19	2	AN80
AW84	AW84X	420	490	560	36	411	32	4	23	250	19	2	AN84
AW88	AW88X	440	510	580	40	431	36	4	23	269	19	2	AN88
AW92	AW92X	460	540	600	40	451	36	4	25	295	19	2	AN92
AW96	AW96X	480	560	640	40	471	36	4	25	335	19	2	AN96
AW100	AW100X	500	580	650	44	491	40	4	25	340	19	2	AN100

Lockwashers

Lockwashers

Series
AWL

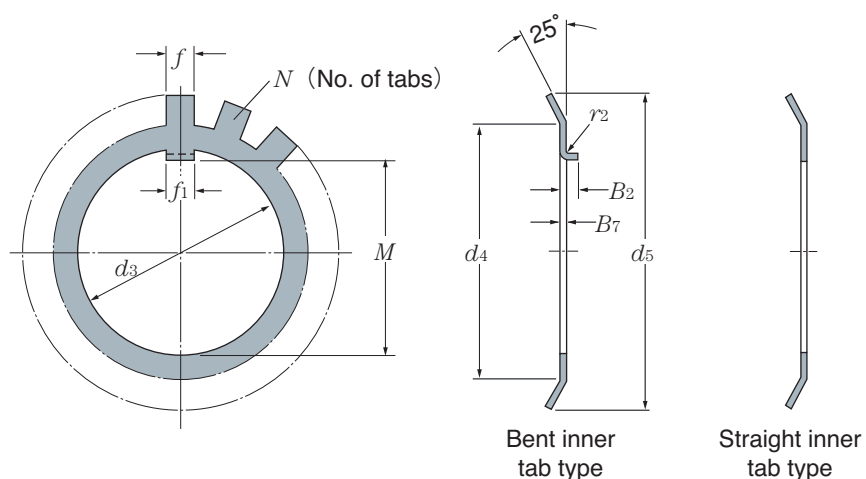

Part numbers		Dimensions mm								Mass kg (approx.) 100 pieces	Dimensions mm		Applicable Locknut numbers
Bent inner tab type	Straight inner tab type	d_3	d_4	d_5	f_1	M	f	B_7	N		Bent inner tab type B_2	r_2	
AWL24	AWL24X	120	133	155	14	115	12	2	19	7.70	8	1.5	ANL24
AWL26	AWL26X	130	143	165	14	125	12	2	19	8.70	8	1.5	ANL26
AWL28	AWL28X	140	151	175	16	135	14	2	19	10.9	10	1.5	ANL28
AWL30	AWL30X	150	164	190	16	145	14	2	19	11.3	10	1.5	ANL30
AWL32	AWL32X	160	174	200	18	154	16	2.5	19	16.2	10.5	1.5	ANL32
AWL34	AWL34X	170	184	210	18	164	16	2.5	19	19.0	10.5	1.5	ANL34
AWL36	AWL36X	180	192	220	20	174	18	2.5	19	18.0	10.5	1.5	ANL36
AWL38	AWL38X	190	202	230	20	184	18	2.5	19	20.5	10.5	1.5	ANL38
AWL40	AWL40X	200	218	250	20	194	18	2.5	19	21.4	10.5	1.5	ANL40
AWL44	AWL44X	220	242	272	24	213	20	3	19	34.4	13	1.5	ANL44
AWL48	AWL48X	240	270	302	24	233	20	3	19	45.0	13	1.5	ANL48
AWL52	AWL52X	260	290	322	24	253	20	3	23	50.5	18	1.5	ANL52
AWL56	AWL56X	280	310	342	28	273	24	3	23	56.7	18	1.5	ANL56
AWL60	AWL60X	300	336	375	28	293	24	3	23	71.6	18	1.5	ANL60
AWL64	AWL64X	320	356	395	28	311	24	4	23	99.0	19	2	ANL64
AWL68	AWL68X	340	376	415	28	331	24	4	23	103	19	2	ANL68
AWL72	AWL72X	360	394	435	32	351	28	4	23	111	19	2	ANL72
AWL76	AWL76X	380	422	465	32	371	28	4	23	133	19	2	ANL76
AWL80	AWL80X	400	442	485	32	391	28	4	23	137	19	2	ANL80
AWL84	AWL84X	420	462	505	36	411	32	4	23	149	19	2	ANL84
AWL88	AWL88X	440	490	535	36	431	32	4	23	175	19	2	ANL88
AWL92	AWL92X	460	510	555	36	451	32	4	25	185	19	2	ANL92
AWL96	AWL96X	480	530	575	40	471	36	4	25	198	19	2	ANL96
AWL100	AWL100X	500	550	595	40	491	36	4	25	203	19	2	ANL100

Note : Narrow slit type adapter sleeves appended with the code suffix "X" after the H (HE)30 and H39 part numbers use straight inner tab washers.

Wide slit type adapter sleeves without the suffix code "X" after the adapter part number can use either bent inner tab washers or straight inner tab washers.

Lockplates

Lockplates

Series

AL

ALL

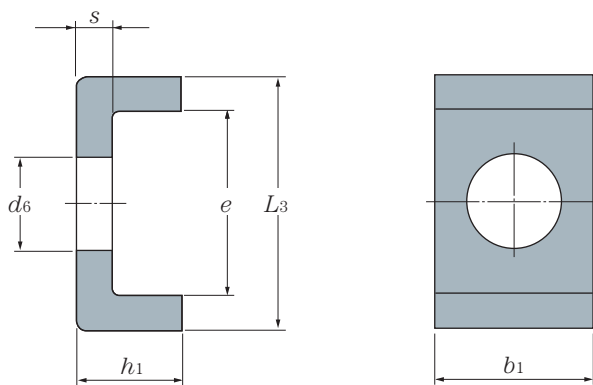

Part numbers	Dimensions mm								Mass kg (approx.) 100 pieces	Applicable Locknut numbers
	s	b ₁	h ₁	d ₆	e	l ①	G ₂ ②	L ₃		
AL44	4	20	12	9	22.5	16	M8	30.5	2.60	AN44, AN48
AL52	4	24	12	12	25.5	20	M10	33.5	3.39	AN52, AN56
AL60	4	24	12	12	30.5	20	M10	38.5	3.79	AN60
AL64	5	24	15	12	31	20	M10	41	5.35	AN64
AL68	5	28	15	14	38	25	M12	48	6.65	AN68, AN72
AL76	5	32	15	14	40	25	M12	50	7.96	AN76
AL80	5	32	15	18	45	30	M16	55	8.20	AN80, AN84
AL88	5	36	15	18	43	30	M16	53	9.00	AN88, AN92
AL96	5	36	15	18	53	30	M16	63	10.4	AN96
AL100	5	40	15	18	45	30	M16	55	10.5	AN100
AL106	7	40	21	22	51	40	M20	65	15.3	AN106
AL112	7	45	21	22	54	40	M20	68	18.2	AN112

① l dimensions indicate reference dimensions for the length of fastening bolts of clasps.

② G₂ dimensions indicate reference dimensions for the thread of fastening bolts of clasps.

Note : This series uses series H31, H32 and H23 adapters.

Part numbers	Dimensions mm								Mass kg (approx.) 100 pieces	Applicable Locknut numbers
	s	b ₁	h ₁	d ₆	e	l ①	G ₂ ②	L ₃		
ALL44	4	20	12	7	13.5	12	M6	21.5	2.12	ANL44
ALL48	4	20	12	9	17.5	16	M8	25.5	2.29	ANL48, ANL52
ALL56	4	24	12	9	17.5	16	M8	25.5	2.92	ANL56
ALL60	4	24	12	9	20.5	16	M8	28.5	3.16	ANL60
ALL64	5	24	15	9	21	16	M8	31	4.56	ANL64, ANL68
ALL72	5	28	15	9	20	16	M8	30	5.03	ANL72
ALL76	5	28	15	12	24	20	M10	34	5.28	ANL76, ANL80
ALL84	5	32	15	12	24	20	M10	34	6.11	ANL84
ALL88	5	32	15	14	28	25	M12	38	6.45	ANL88, ANL92
ALL96	5	36	15	14	28	25	M12	38	7.29	ANL96, ANL100
ALL106	7	40	21	18	34	30	M16	48	15.3	ANL106, ANL120
ALL112	7	40	21	18	29	30	M16	43	14.2	ANL112
ALL126	7	45	21	18	34	30	M16	48	17.4	ANL126

① l dimensions indicate reference dimensions for the length of fastening bolts of clasps.

② G₂ dimensions indicate reference dimensions for the thread of fastening bolts of clasps.

Note : This series uses series H30 and H39 adapters.

Hydraulic Nuts

Hydraulic Nuts

Series
HPN

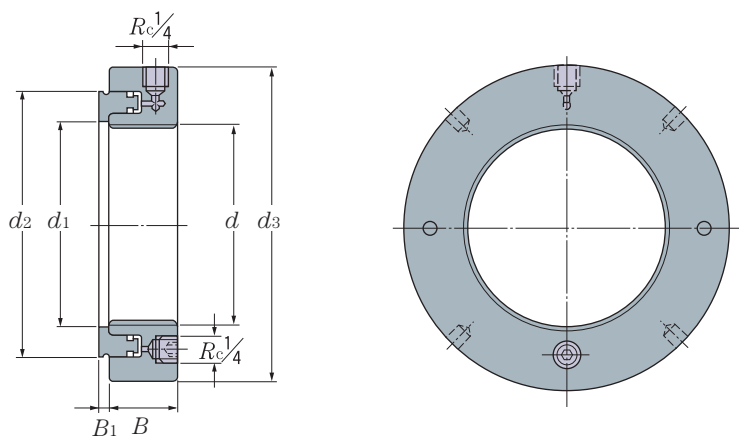

Part numbers	Dimensions mm						Plunger Travel Length max mm	Plunger Effective Area mm ²	Mass kg (approx.)
	Thread ①	d	d_1	d_2	d_3	B			
HPN18	M90×2	90.5	127	156	38	5	5	4 700	4.00
HPN19	M95×2	95.5	133	162	38	5	5	4 900	4.30
HPN20	M100×2	100.5	138	166	38	6	5	5 100	4.40
HPN21	M105×2	105.5	143	172	38	6	5	5 300	4.65
HPN22	M110×2	110.5	149	178	38	6	5	5 600	4.95
HPN23	M115×2	115.5	154	182	38	6	5	5 800	5.00
HPN24	M120×2	120.5	159	188	38	6	5	6 000	5.25
HPN25	M125×2	125.5	164	192	38	6	5	6 200	5.35
HPN26	M130×2	130.5	170	198	38	6	5	6 400	5.65
HPN27	M135×2	135.5	175	204	38	6	5	6 600	5.90
HPN28	M140×2	140.5	180	208	38	7	5	6 800	6.00
HPN29	M145×2	145.5	186	214	39	7	5	7 300	6.50
HPN30	M150×2	150.5	191	220	39	7	5	7 500	6.60
HPN31	M155×3	155.5	198	226	39	7	5	8 100	6.95
HPN32	M160×3	160.5	204	232	40	7	6	8 600	7.60
HPN33	M165×3	165.5	209	238	40	7	6	8 900	7.90
HPN34	M170×3	170.5	215	244	41	7	6	9 400	8.40
HPN36	M180×3	180.5	227	256	41	7	6	10 300	9.15
HPN38	M190×3	191	239	270	42	8	7	11 500	10.5
HPN40	M200×3	201	251	282	43	8	8	12 500	11.5
HPN41	Tr205×4	207	256	288	43	8	8	12 800	12.0
HPN42	Tr210×4	212	262	294	44	8	9	13 400	12.5
HPN43	Tr215×4	217	267	300	44	8	9	13 700	13.0
HPN44	Tr220×4	222	273	306	44	8	9	14 400	13.5
HPN45	Tr225×4	227	280	312	45	8	9	15 200	14.5
HPN46	Tr230×4	232	285	318	45	8	9	15 500	14.5
HPN47	Tr235×4	237	291	326	46	8	10	16 200	16.0
HPN48	Tr240×4	242	296	330	46	9	10	16 500	16.0
HPN50	Tr250×4	252	307	342	46	9	10	17 600	17.5
HPN52	Tr260×4	262	319	356	47	9	11	18 800	19.0
HPN54	Tr270×4	272	330	368	48	9	12	19 800	20.5
HPN56	Tr280×4	282	341	380	49	9	12	21 100	22.0
HPN58	Tr290×4	292	353	390	49	9	13	22 400	22.5

① Standard thread shapes and dimensions of the part numbers **HPN18** to **HPN40** are as per JIS B 0205-1 and JIS B 0205-4 (general purpose metric screw threads).
Standard thread shapes and dimensions of the part numbers **HPN41** to **HPN126** are as per JIS B 0216 (metric trapezoidal screw threads).

Hydraulic Nuts

Part numbers	Dimensions mm						Plunger Travel Length max mm	Plunger Effective Area mm ²	Mass kg (approx.)
	Thread ①	<i>d</i>	<i>d</i> ₁	<i>d</i> ₂	<i>d</i> ₃	<i>B</i>			
HPN60	Tr300×4	302	364	404	51	10	14	23 600	25.5
HPN62	Tr310×5	312	375	416	52	10	14	24 900	27.0
HPN64	Tr320×5	322	387	428	53	10	14	26 300	29.5
HPN66	Tr330×5	332	397	438	53	10	14	27 000	30.0
HPN68	Tr340×5	342	408	450	54	10	14	28 400	31.5
HPN69	Tr345×5	347	414	456	54	10	14	29 400	32.5
HPN70	Tr350×5	352	420	464	56	10	14	29 900	35.0
HPN72	Tr360×5	362	431	472	56	10	15	31 300	35.5
HPN73	Tr365×5	367	436	482	57	11	15	31 700	38.5
HPN74	Tr370×5	372	442	486	57	11	16	32 800	39.0
HPN76	Tr380×5	382	452	498	58	11	16	33 500	40.5
HPN77	Tr385×5	387	459	504	58	11	16	34 700	41.0
HPN80	Tr400×5	402	475	522	60	11	17	36 700	45.5
HPN82	Tr410×5	412	486	534	61	11	17	38 300	48.0
HPN84	Tr420×5	422	498	546	61	11	17	40 000	50.0
HPN86	Tr430×5	432	508	556	62	11	17	40 800	52.5
HPN88	Tr440×5	442	519	566	62	12	17	42 500	54.0
HPN90	Tr450×5	452	530	580	64	12	17	44 100	57.5
HPN92	Tr460×5	462	541	590	64	12	17	45 100	60.0
HPN94	Tr470×5	472	552	602	65	12	18	46 900	62.0
HPN96	Tr480×5	482	563	612	65	12	19	48 600	63.0
HPN98	Tr490×5	492	573	624	66	12	19	49 500	66.0
HPN100	Tr500×5	502	585	636	67	12	19	51 500	70.0
HPN102	Tr510×6	512	596	648	68	12	20	53 300	74.0
HPN104	Tr520×6	522	606	658	68	13	20	54 300	75.0
HPN106	Tr530×6	532	617	670	69	13	21	56 200	79.0
HPN108	Tr540×6	542	629	682	69	13	21	58 200	81.0
HPN110	Tr550×6	552	639	693	70	13	21	59 200	84.0
HPN112	Tr560×6	562	650	704	71	13	22	61 200	88.0
HPN114	Tr570×6	572	661	716	72	13	23	63 200	91.0
HPN116	Tr580×6	582	671	726	72	13	23	64 200	94.0
HPN120	Tr600×6	602	693	748	73	13	23	67 300	100
HPN126	Tr630×6	632	726	782	74	14	23	72 900	110

Protective Plates

Protective Plates

Series

ANP

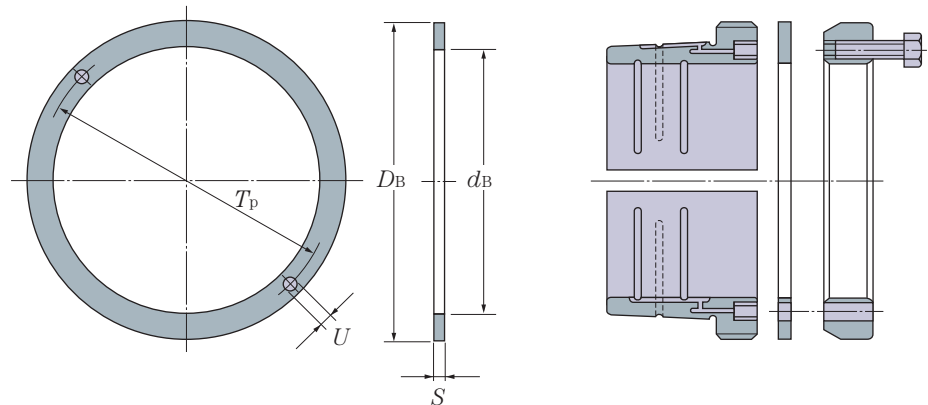

Part numbers	Dimensions mm					Mass kg (approx.)	Applicable Locknut numbers	
	d_B	D_B	S	U	T_P		Series AN	Series ANL
ANP40	202	234	2	12	217	0.172	AN40SPB	—
ANP44	222	268	2.5	12	237	0.347	AN44SPB	ANL44SPB
ANP48	242	285	2.5	12	257	0.349	AN48SPB	ANL48SPB
ANP52	262	305	2.5	12	277	0.376	AN52SPB	ANL52SPB
ANP56	282	326	2.5	12	297	0.412	AN56SPB	ANL56SPB
ANP60	302	356	2.5	12	317	0.547	AN60SPB	ANL60SPB
ANP64	322	376	2.5	12	337	0.581	AN64SPB	ANL64SPB
ANP68	342	410	2.5	12	357	0.788	AN68SPB	ANL68SPB
ANP72	362	430	2.5	12	377	0.830	AN72SPB	ANL72SPB
ANP76	382	454	2.5	12	397	0.927	AN76SPB	ANL76SPB
ANP80	402	484	2.5	12	417	1.12	AN80SPB	ANL80SPB
ANP84	422	504	2.5	12	437	1.17	AN84SPB	ANL84SPB
ANP88	442	520	2.5	12	457	1.16	AN88SPB	ANL88SPB
ANP92	462	540	2.5	12	477	1.2	AN92SPB	ANL92SPB
ANP96	482	580	2.5	12	497	1.6	AN96SPB	ANL96SPB
ANP100	502	584	2.5	15	524	1.4	AN100SPB	ANL100SPB
ANP106	532	630	3	15	554	2.1	AN106SPB	ANL106SPB
ANP114	572	680	3	15	594	2.5	AN114SPB	ANL114SPB

Note : Applicable hydraulic sleeve nuts are listed on P36 to 43.

Tr Thread Dimensions

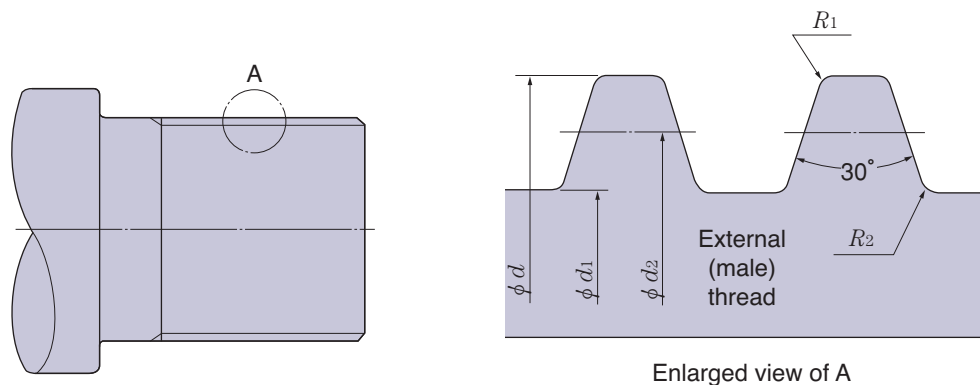

Tr male thread allowable limit dimensions and rounding radii

Thread	Major Diameter d		Pitch Diameter d_2		Minor Diameter d_1		Rounded Peak Radius R_1	Rounded Valley Radius R_2
	Max	Min	Max	Min	Max	Min	Max	Max
Tr220×4	220.000	219.700	217.905	217.570	215.500	214.986	R0.125	R0.25
Tr240×4	240.000	239.700	237.905	237.570	235.500	234.986		
Tr260×4	260.000	259.700	257.905	257.570	255.500	254.986		
Tr280×4	280.000	279.700	277.905	277.570	275.500	274.986		
Tr300×4	300.000	299.700	297.905	297.570	295.500	294.986		
Tr320×5	320.000	319.665	317.394	317.019	314.500	313.925		
Tr340×5	340.000	339.665	337.394	337.019	334.500	333.925		
Tr360×5	360.000	359.665	357.394	356.994	354.500	353.894		
Tr380×5	380.000	379.665	377.394	376.994	374.500	373.894		
Tr400×5	400.000	399.665	397.394	396.994	394.500	393.894		
Tr410×5	410.000	409.665	407.394	406.994	404.500	403.894		
Tr420×5	420.000	419.665	417.394	416.994	414.500	413.894		
Tr430×5	430.000	429.665	427.394	426.994	424.500	423.894		
Tr440×5	440.000	439.665	437.394	436.994	434.500	433.894		
Tr450×5	450.000	449.665	447.394	446.994	444.500	443.894		
Tr460×5	460.000	459.665	457.394	456.994	454.500	453.894		
Tr470×5	470.000	469.665	467.394	466.994	464.500	463.894		
Tr480×5	480.000	479.665	477.394	476.994	474.500	473.894		
Tr500×5	500.000	499.665	497.394	496.994	494.500	493.894		
Tr530×5	530.000	529.625	526.882	526.457	523.000	522.351	R0.25	R0.5
Tr560×6	560.000	559.625	556.882	556.457	553.000	552.351		
Tr570×6	570.000	569.625	566.882	566.457	563.000	562.351		
Tr600×6	600.000	599.625	596.882	596.457	593.000	592.351		
Tr630×6	630.000	629.625	626.882	626.457	623.000	622.351		

• The values for the allowable limit dimensions above do not include thread shape errors or pitch errors (total cumulative errors). When manufacturing Tr threads, the lower limit of the above allowable limit dimensions are to be used where possible for machining.

Note : These values were calculated with class 7e from JIS B 0217 (metric trapezoidal screw threads).

4. Handling

Page

(1) Installation/removal of adapter sleeves using locknuts	55
(2) Installation/removal of bearings using hydraulic sleeves	57
(3) Installation/removal of bearings using hydraulic nuts.....	60

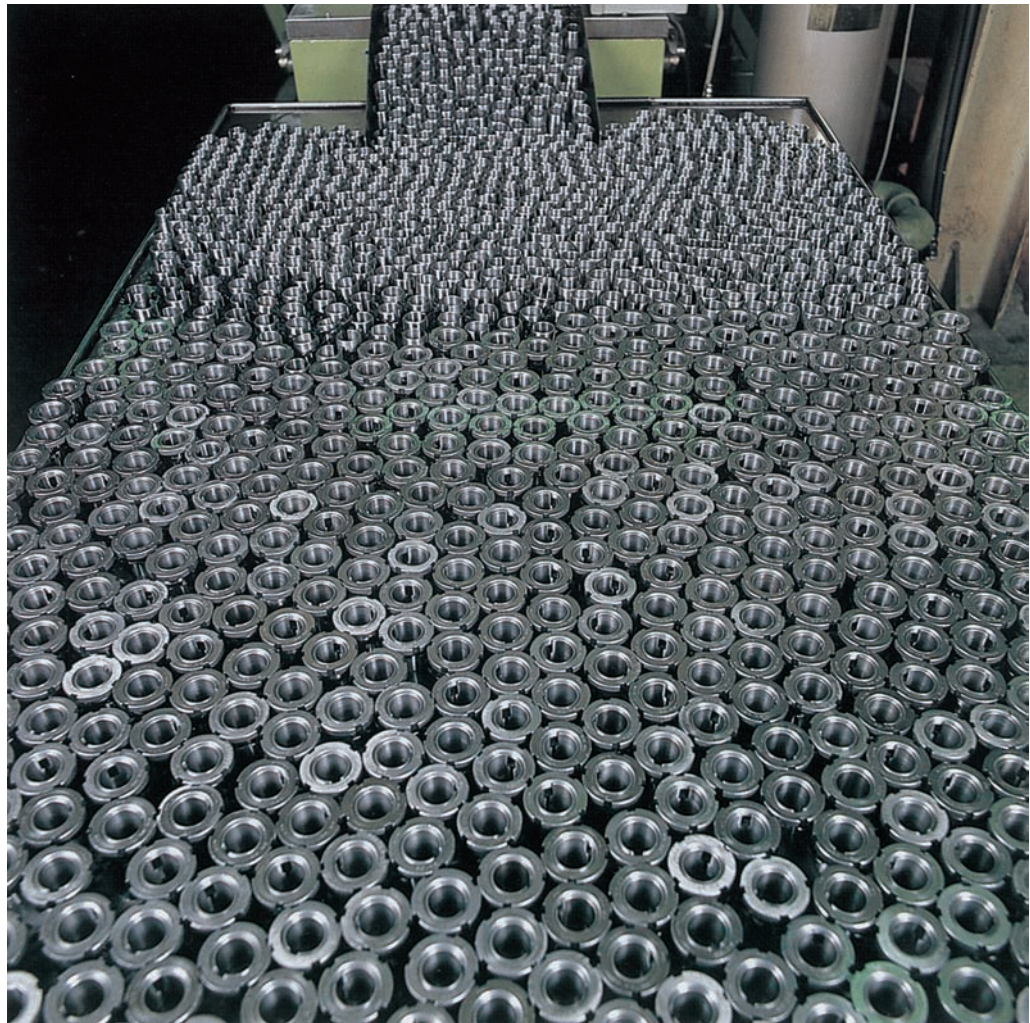

(1) Installation/removal of adapter sleeves using locknuts

Using adapters to mount bearings onto shafts makes installation and positioning easier, while maintaining the appropriate level of holding force needed. Incorrect installation methods may cause damage when running the bearings, so care is required during installation.

Withdrawal sleeves can be handled in the same way as adapters, however the following procedures mainly outline the handling method for adapters.

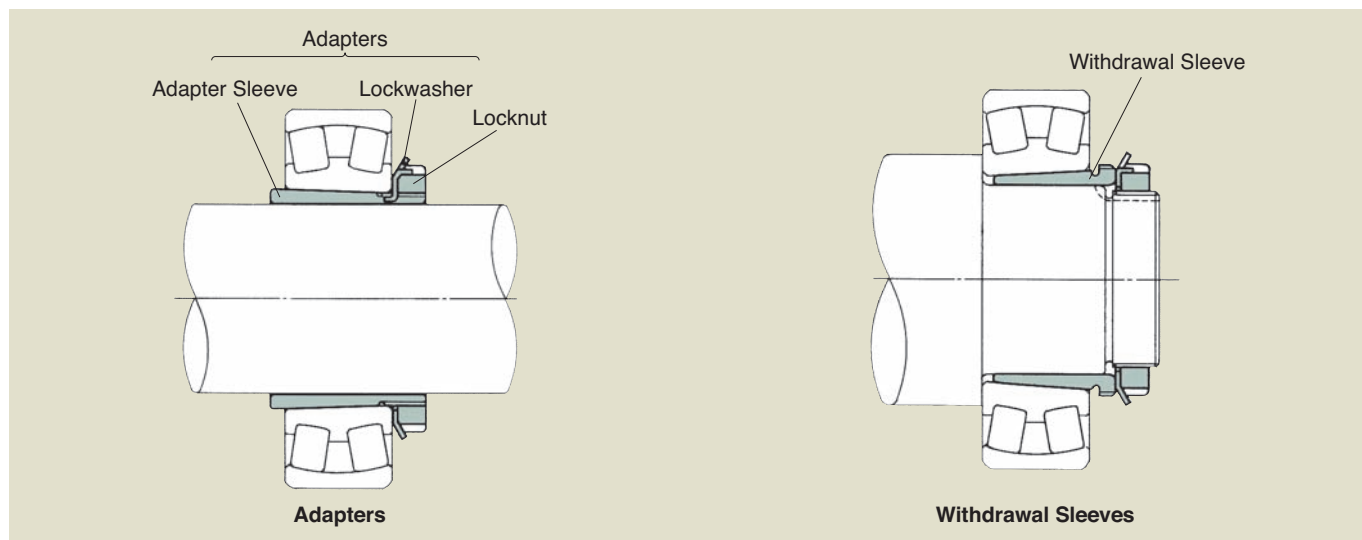

Fig. 1

1. Preparation

- (1) Prepare the relevant tools and lubricants required for assembly work (see Fig. 2).

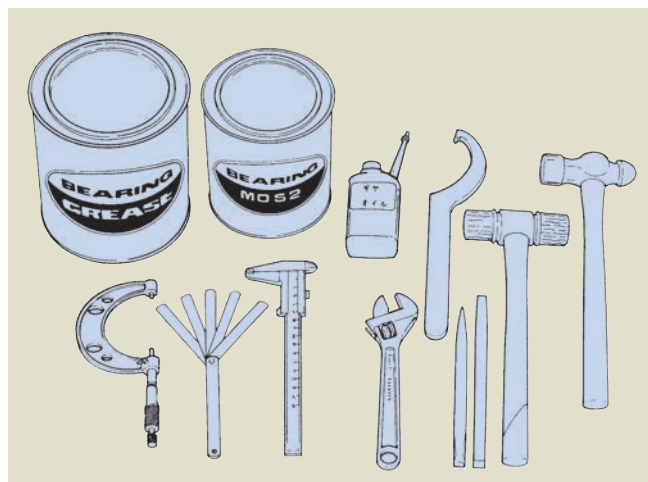

Fig. 2

- (2) Verify the part number of the bearings and adapters being installed, and check that the adapter and dimensions are suitable for the shaft diameter.
- (3) Clean the shafts that the adapters will be installed on. Check that the shaft diameter measurements are within the specified appropriate tolerance (see Fig. 3).
- (4) Adapters have rust inhibitor applied to the surface. After removing the adapters from their packaging, wipe clean any oil using a clean cloth soaked in kerosene.

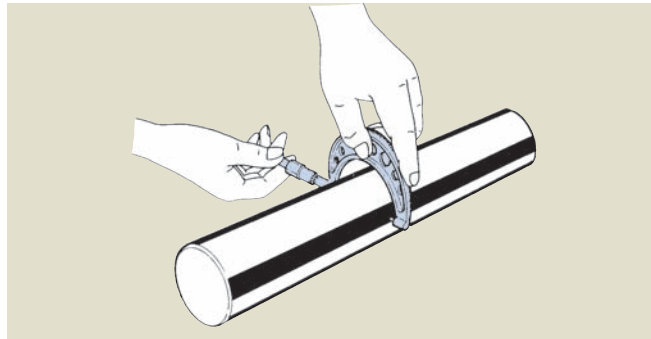

Fig. 3

- (5) To prevent scoring and other damage caused by high surface pressures when fastening components, first apply lubricant containing molybdenum dioxide or extreme-pressure gear oil to the tapered surfaces of sleeves, threads, the side of nuts and other surfaces. Take care that no oil is applied between the shaft and adapter during this step.

If components are assembled immediately after cleaning and then fastened, the poor lubrication between the bearing and shaft contact surfaces as well as fastening threads may result in insufficient fastening caused by scoring on thread peaks before the specified level of fastening is achieved.

2. Installation

- (1) When fitting the adapter to the shaft, use the appropriate wedge to open the split section of the adapter sleeve to make it easier to fit it to the shaft (see Fig. 4).

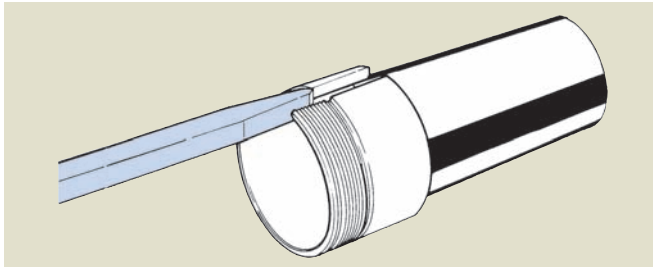

Fig. 4

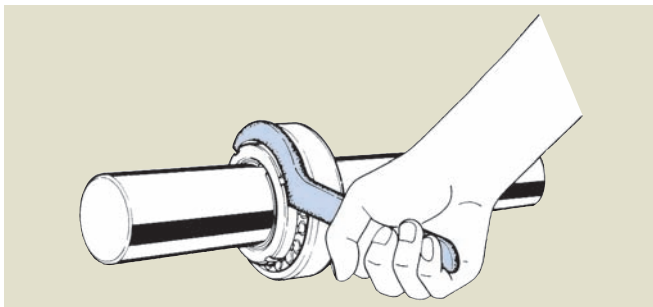

Fig. 5

(2) Using the hook spanner shown in **Fig. 5** makes it convenient to fasten the nut. If a hook spanner is not available, fasten the nut by aligning the end of a suitably sized rod with the notch in the nut and tapping with a hammer, as shown in **Fig. 6**. Hitting it wildly may cause deformation of the notch in the nut or burrs to be formed, damaging the bearing.

Large nuts require a high fastening torque, and washers can be easily damaged when fastening nuts with washers still attached. Remove the washer first before fastening the nut. When using this method, remove the nut after the specified level of fastening has been achieved, fit the washer and fasten the nut again to its original position.

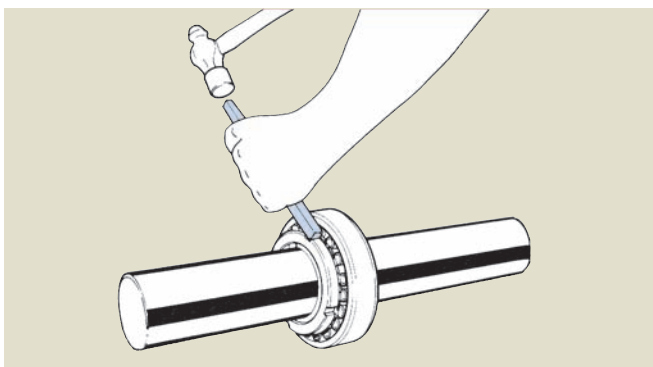

Fig. 6

(3) To check that the specified level of fastening has been achieved, measure how much the bearing radial internal clearance has changed before and after fastening (see **Fig. 7**), or measure the relative amount of axial movement between the adapter and bearing.

See the relevant "Ball and Roller Bearings Catalog" CAT. No. 2202 for details of these values.

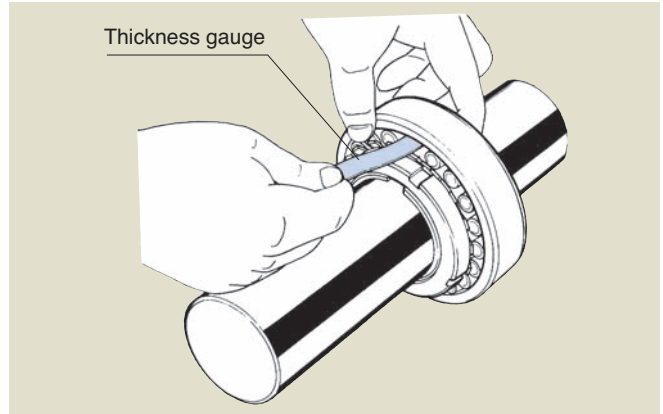
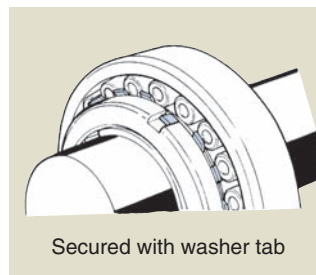

Fig. 7

(4) After fastening, always check that the specified level of fastening above has been achieved, and bend the washer securing tab into the notch in the nut (**Fig. 8**). For large nuts, use a clasp to secure the nut (see **Fig. 9**). When doing so, do not turn the nut backwards so that the tab is aligned with the notch.



Secured with washer tab

Fig. 8

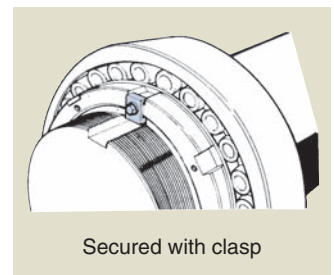

Secured with clasp

Fig. 9

3. Removal

For adapters, first lift the washer tab that is bent into the notch in the nut, and use a hook spanner or rod and hammer to turn the nut 2 to 3 times to loosen it. With the nut loosened, the bearing can be removed easily by aligning the rod against the side of the nut and pushing in the direction for removing the sleeve (see **Fig. 10**).

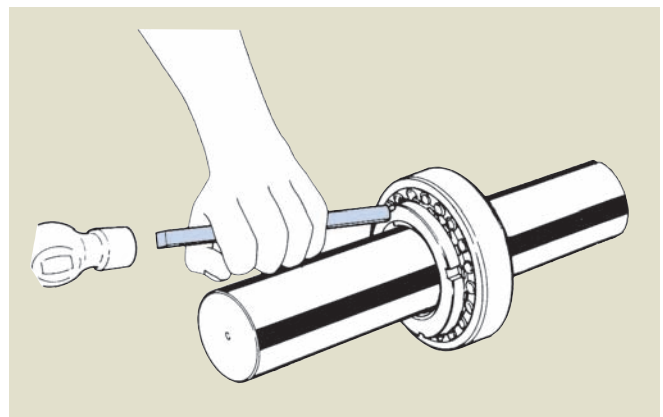

Fig. 10

(2) Installation/removal of bearings using hydraulic sleeves

Using the pressure from a hydraulic pump when installing tapered bore bearings makes it easy to install bearings without applying excessive force. When using either a hydraulic adapter or hydraulic withdrawal sleeves, the eight fastening bolts are to be fastened with equal force.

Hydraulic adapters are to be handled in the same way as hydraulic withdrawal sleeves, however the following procedures mainly outline the handling method for hydraulic withdrawal sleeves.

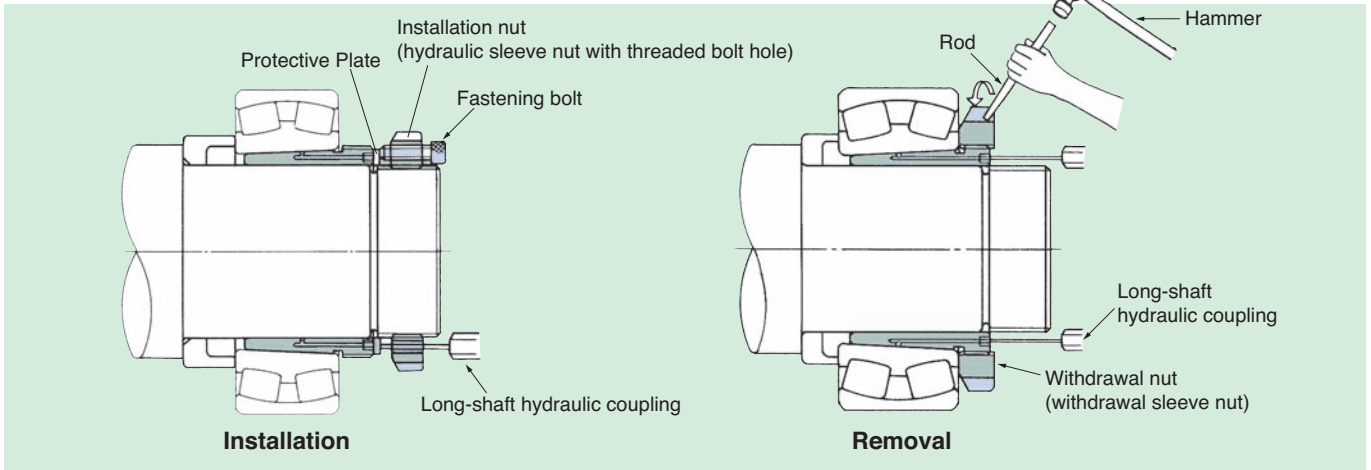

Fig. 11

1. Installation

(1) Preparation

In addition to the items shown in Fig. 2 on P. 55, prepare a hydraulic pump, hydraulic sleeve nut, protective plate and hexagonal bolts (see Fig. 12 and 13).

Set the hydraulic pump to a pressure between 35 to 70 MPa (350 to 700 kgf/cm², 5000 to 10000 lbf/in²) to suit the specific application.

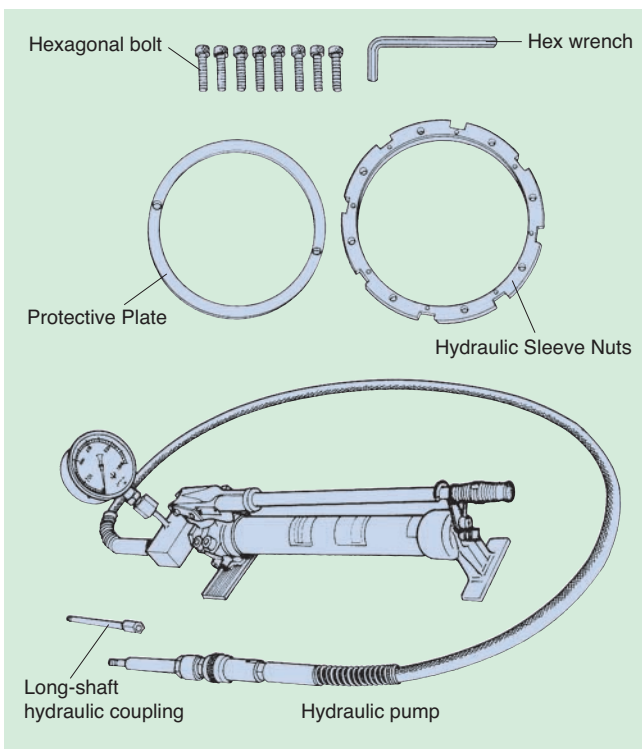

Fig. 12

(2) Install the bearing and hydraulic withdrawal sleeve (see Fig. 13).

Next, set protective plates that suit the shaft they are being mounted to, to both ends of the hydraulic withdrawal sleeve.

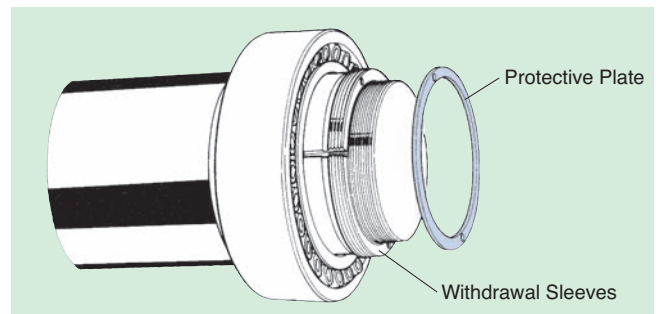

Fig. 13

(3) Prepare an installation nut that suits the shaft it is being

mounted to. First assemble fastening bolts (x8) that have been applied with molybdenum dioxide to the installation nut (see Fig. 14).

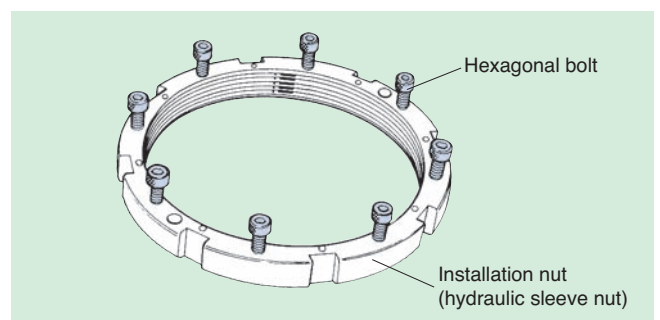

Fig. 14

- (4) Check that the holes in the hydraulic withdrawal sleeve, protective plate and installation nut are aligned along the same shaft, and connect the hose from the long-shaft hydraulic coupling and hydraulic pump (see Fig. 15).

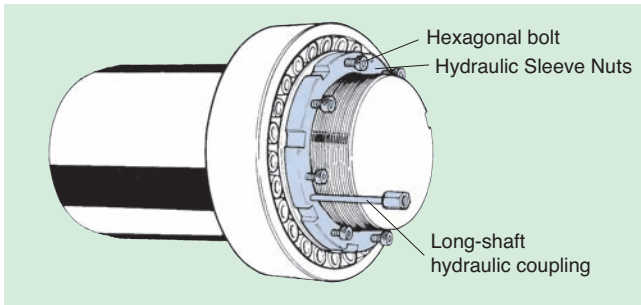

Fig. 15

- (5) Increase the hydraulic pump pressure while tightening the fastening bolts with a spanner and measure the bearing radial internal clearance with a thickness gauge, and tighten the bolts evenly until reaching the specified mounted clearance (see Fig. 16).
Remove the nut and bolt, and secure with the specified washer or clasp.

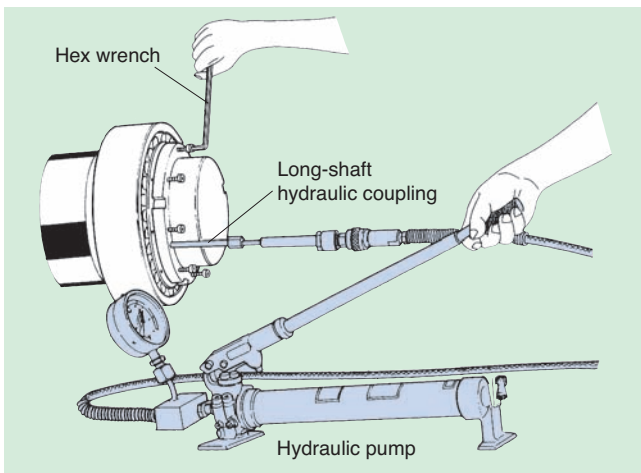

Fig. 16

2. Removal

(1) Preparation

Prepare a hydraulic pump, long-shaft hydraulic coupling, withdrawal nut, rod and hammer (see Fig. 17).

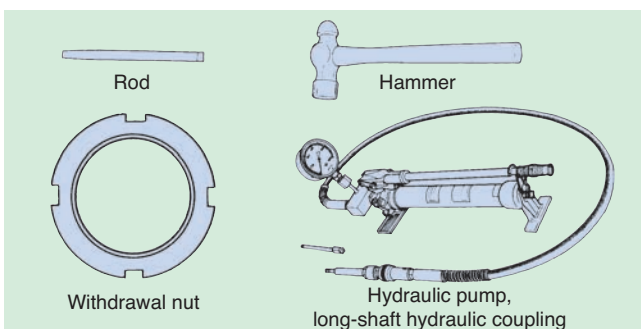

Fig. 17

- (2) Prepare a withdrawal nut that suits the hydraulic withdrawal sleeve, and install it to the thread of the hydraulic withdrawal sleeve (see Fig. 18).
(3) Set the long-shaft hydraulic coupling to the lubrication port at the end of the hydraulic withdrawal sleeve (see Fig. 19).
(4) Connect the hose from the hydraulic pump to the long-shaft hydraulic coupling (see Fig. 19).

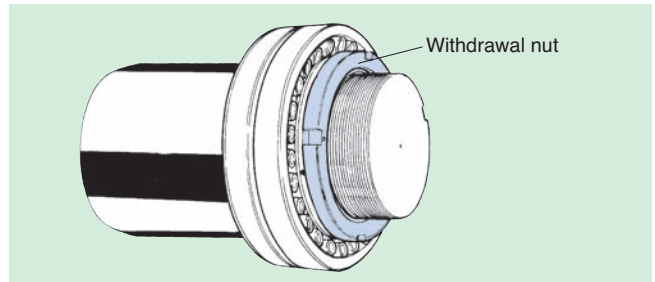

Fig. 18

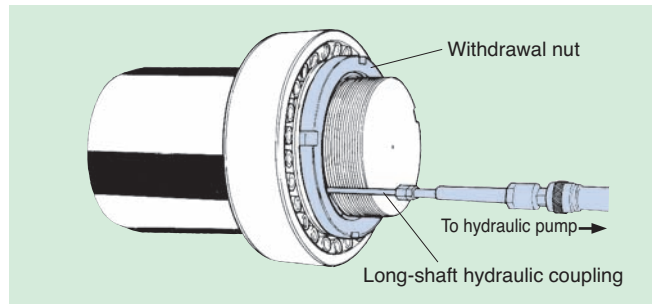

Fig. 19

- (5) Turn the withdrawal nut using the pressure from the hydraulic pump, and remove the hydraulic withdrawal sleeve (see Fig. 20).

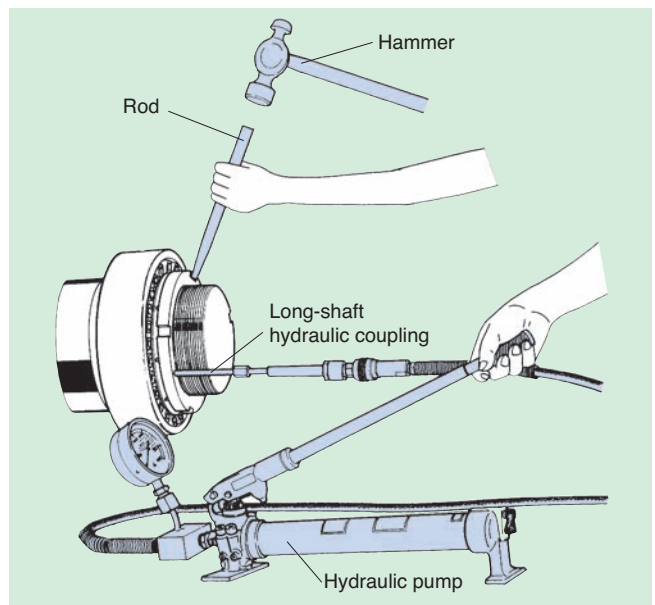

Fig. 20

Tap the four notches in the withdrawal nut using the rod and hammer while applying pressure from the hydraulic pump, and remove the hydraulic withdrawal sleeve.

Example of hydraulic sleeve usage

Bearing installation

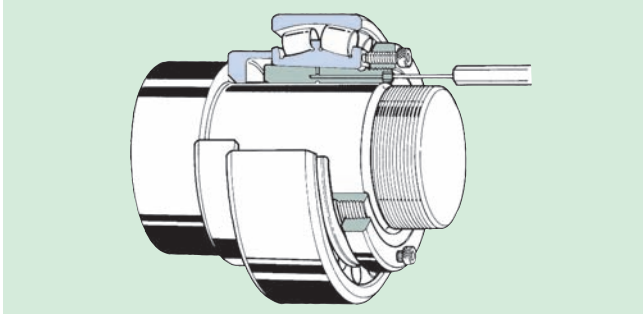

Fig. 21 Hydraulic adapter

Fasten the bolt of the hydraulic sleeve nut and install the bearing.

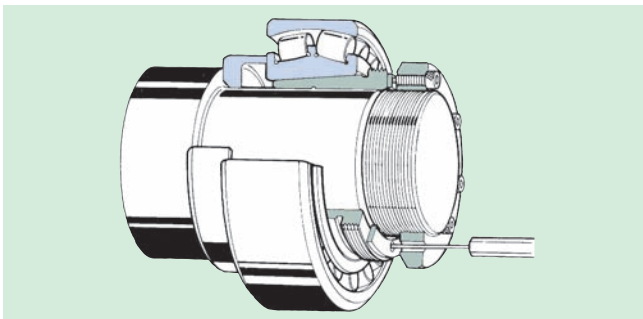

Fig. 22 Hydraulic withdrawal sleeve

Fasten the bolt of the hydraulic sleeve nut and install the bearing through the protective plate.

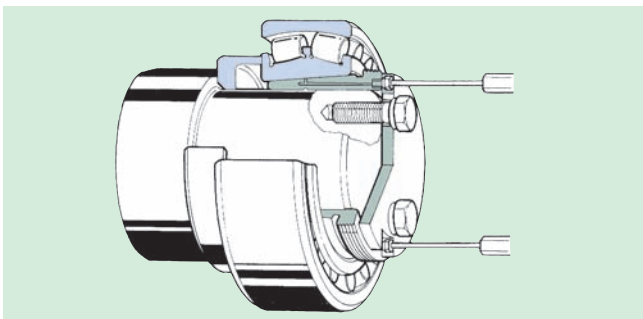

Fig. 23 Hydraulic withdrawal sleeve

Install the bearing through the end plate by fastening the bolt at the end of the shaft.

Bearing removal

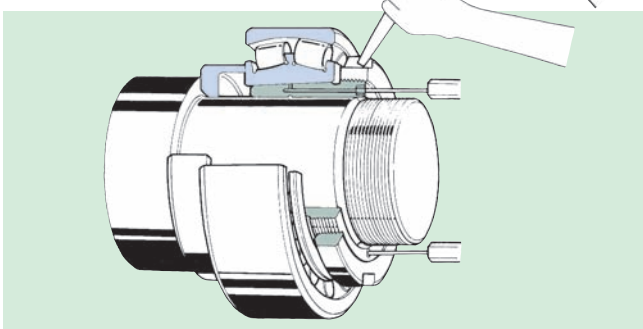

Fig. 24 Hydraulic withdrawal sleeve

Tap the withdrawal sleeve nut with a rod and hammer, and remove the bearing together with the withdrawal sleeve.

(3) Installation/removal of bearings using hydraulic nuts

Installing tapered bore bearings directly onto shafts or using adapters or withdrawal sleeves and removing them from shafts requires high pressure forces and pulling forces. Using hydraulic nuts prevents excessive force from being applied that would damage shafts and bearings, while applying large, equal forces for installation and removal work.

Adapter sleeves are to be handled in the same way as withdrawal sleeves, however the following procedures mainly outline the handling method for withdrawal sleeves.

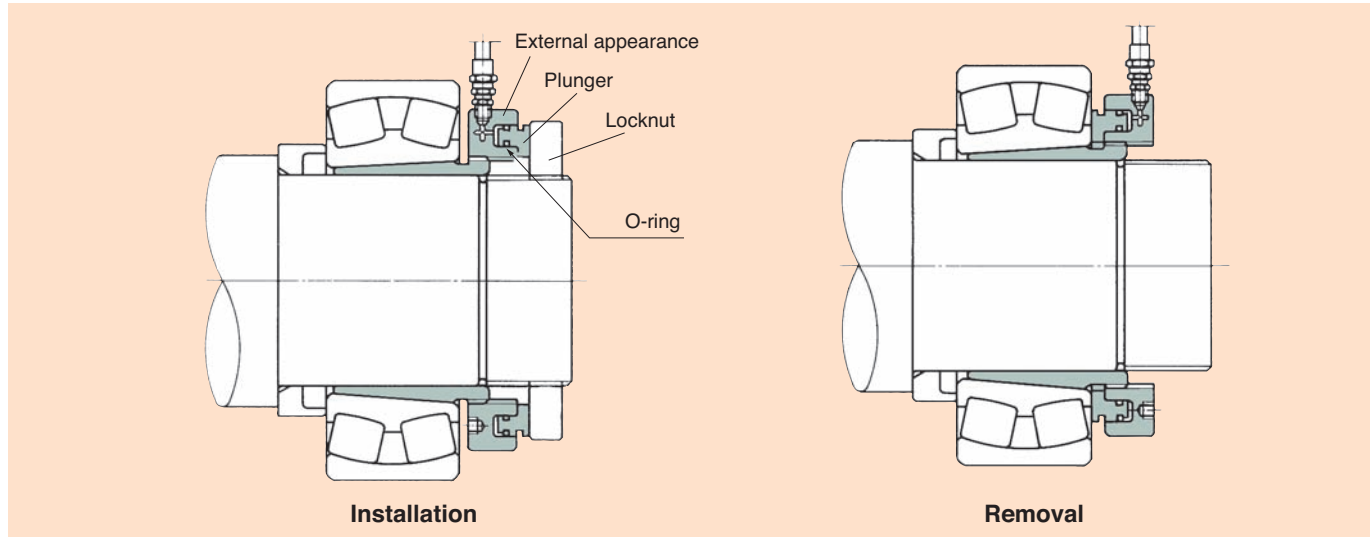

Fig. 25

1. Preparation

Prepare the relevant tools and hydraulic pumps required for assembly and removal work (see Fig. 2 on P55). Other precautions are the same as those listed under 1. Preparation on P. 55.

2. Confirmation

Check each boundary dimension of parts such as bearings, hydraulic nuts, locknuts and withdrawal sleeves (see Fig. 26, 27, 28).

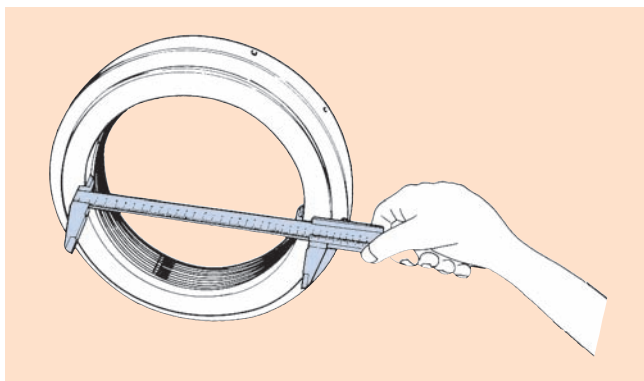

Fig. 26

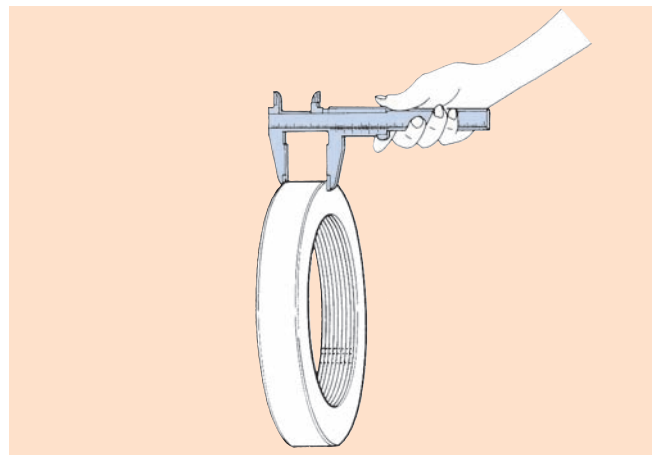

Fig. 27

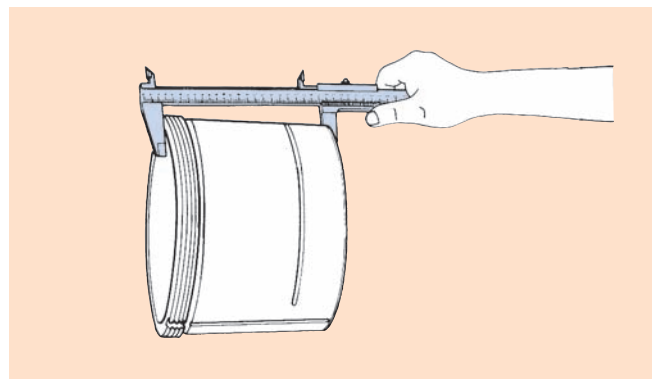

Fig. 28

3. Installation

(1) With the bearing moving free before installation (before fastening), measure the radial internal clearance with a thickness gauge (see Fig. 29). Measure the bearing clearance at three or more points around the bearing, and take the average value.

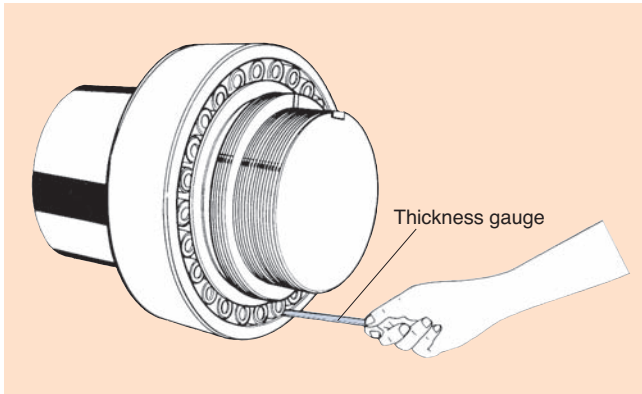

Fig. 29

(2) After installing the hydraulic nut, install a locknut that suits the installation shaft as shown in Fig. 30.

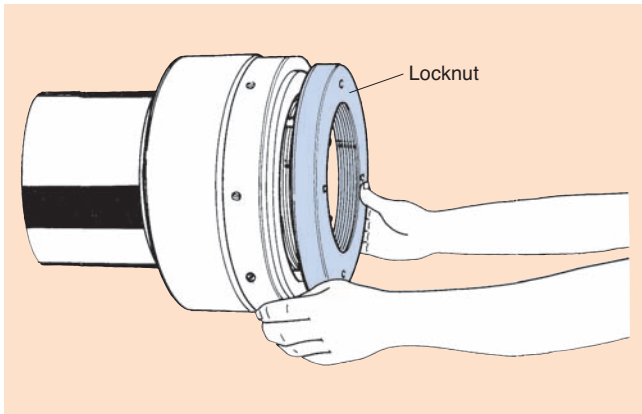

Fig. 30

(3) Connect the hose from the hydraulic pump to the hydraulic nut using a hydraulic coupling (see Fig. 31).

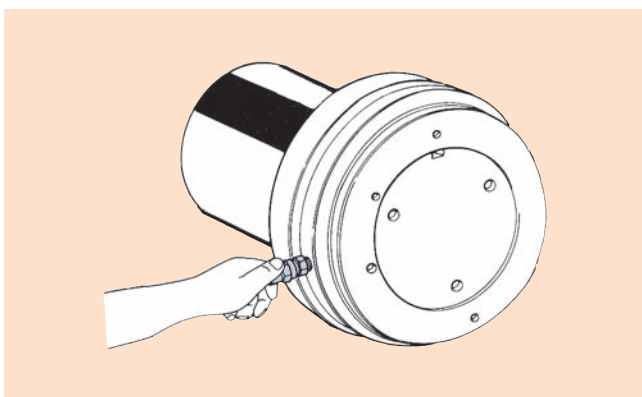

Fig. 31

(4) Measure the bearing radial internal clearance with a thickness gauge, and increase the hydraulic pump pressure until reaching the specified mounted clearance (see Fig. 32).

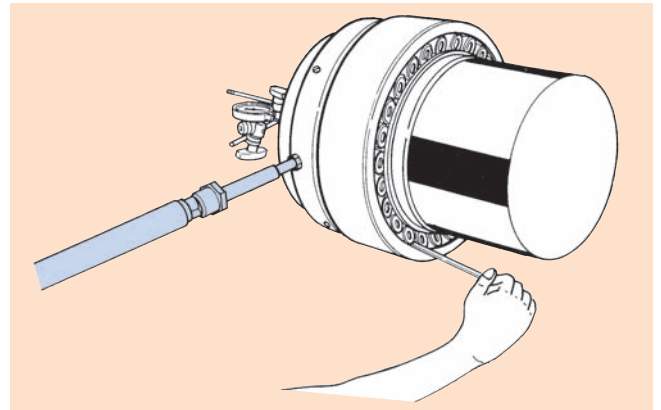

Fig. 32

(5) Remove the locknut and hydraulic nut, set a washer that suits the installation shaft, fasten the shaft nut and bend the washer tab into the notch in the nut to secure it. For large nuts, use a clasp to secure the nut (see Fig. 33).

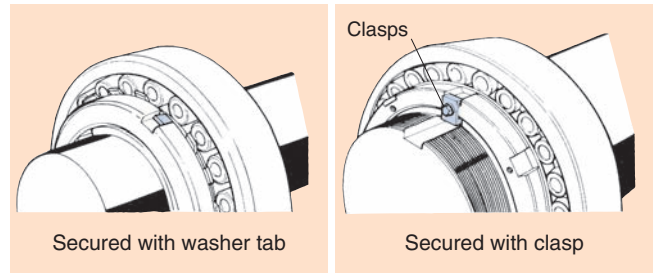

Fig. 33

4. Removal

Install a hydraulic nut to the thread of the withdrawal sleeve, and remove the withdrawal sleeve from the bearing using the hydraulic pump pressure (see Fig. 34). When doing so, install the bearing so that it makes contact with the plunger side of the hydraulic nut.

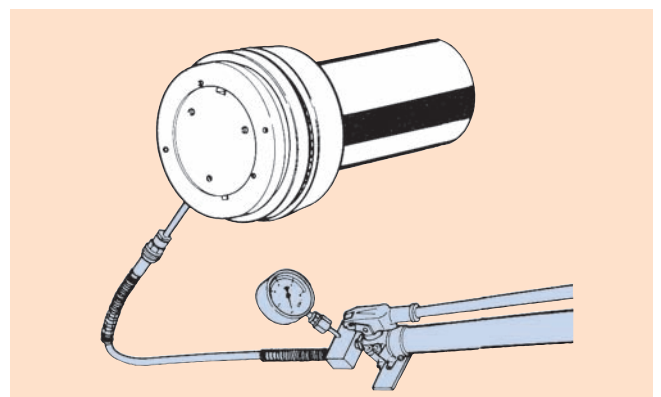

Fig. 34

Example of hydraulic nut usage

Bearing installation

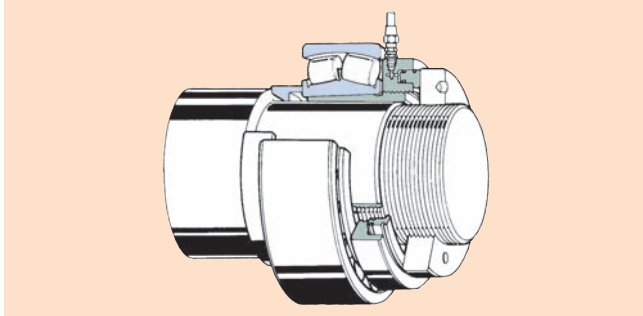

Fig. 35 Using a locknut

Screw the hydraulic nut onto the withdrawal sleeve, turn the locknut on the shaft thread until it makes contact with the plunger, and increase pressure to press the sleeve.

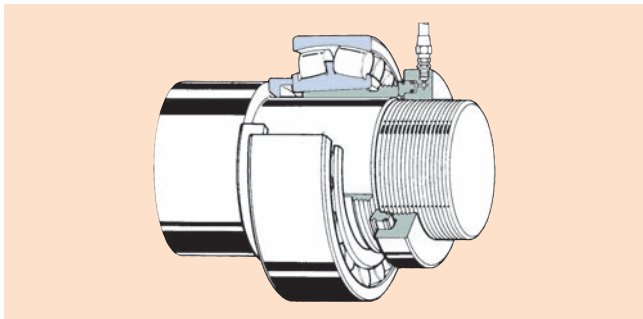

Fig. 36 Using the installation shaft thread

Turn the hydraulic nut on the shaft thread so that the plunger makes contact with the side of the withdrawal sleeve, and increase pressure to press the sleeve.

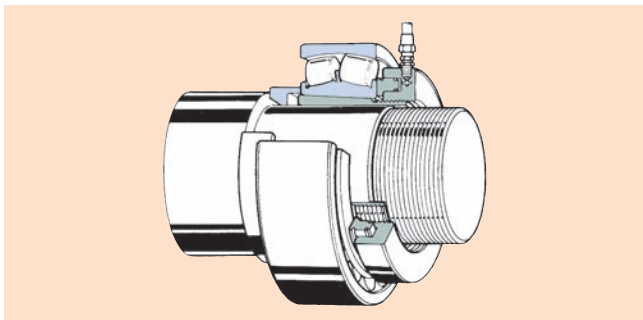

Fig. 37 Using the adapter sleeve thread

Turn the hydraulic nut on the adapter sleeve so that the plunger makes contact with the side of the bearing, and increase pressure to press the bearing.

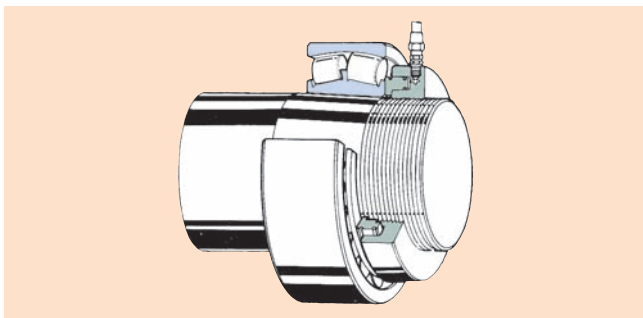

Fig. 38 Using the tapered bearing thread

Turn the hydraulic nut on the shaft thread so that the plunger makes contact with the side of the bearing, and increase pressure to press the bearing.

Bearing removal

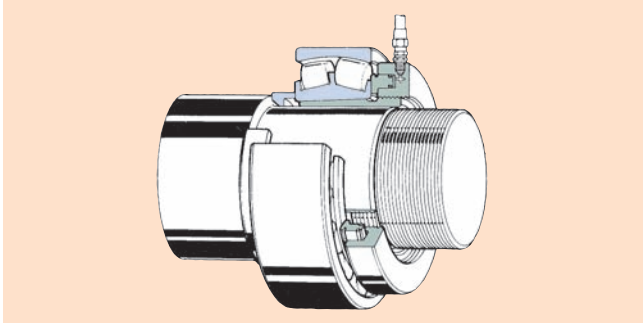

Fig. 39 Using the withdrawal sleeve thread

Turn the hydraulic nut on the withdrawal sleeve so that the plunger makes contact with the side of the bearing, and increase pressure to pull out the withdrawal sleeve.

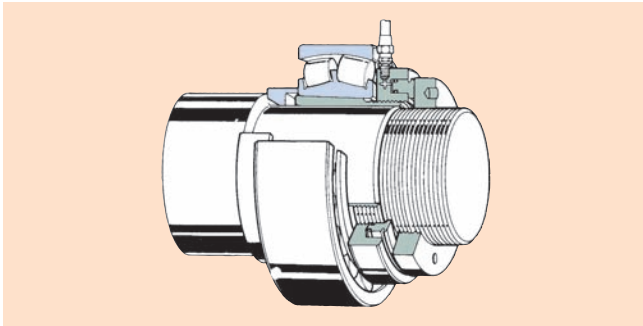

Fig. 40 Using a locknut

Install the hydraulic nut to the adapter sleeve (maintain clearance between the bearing and the side of the hydraulic nut), turn the locknut until it makes contact with the locknut, and increase pressure to press the sleeve..

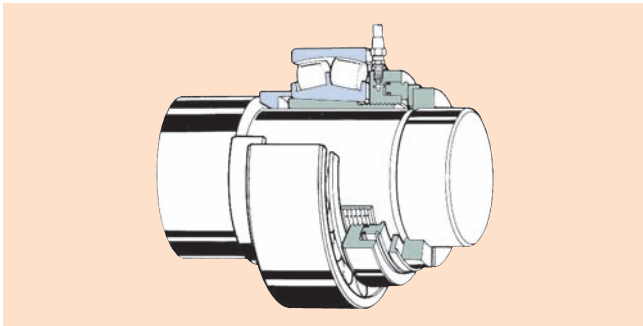

Fig. 41 Using a stop ring

Turn the hydraulic nut on the adapter sleeve (maintain clearance between the bearing and the side of the hydraulic nut), and secure the stop ring with the shaft groove. Increase pressure to press the sleeve through the stop ring.